

# Temperature Regulators Type 8 and Type 9

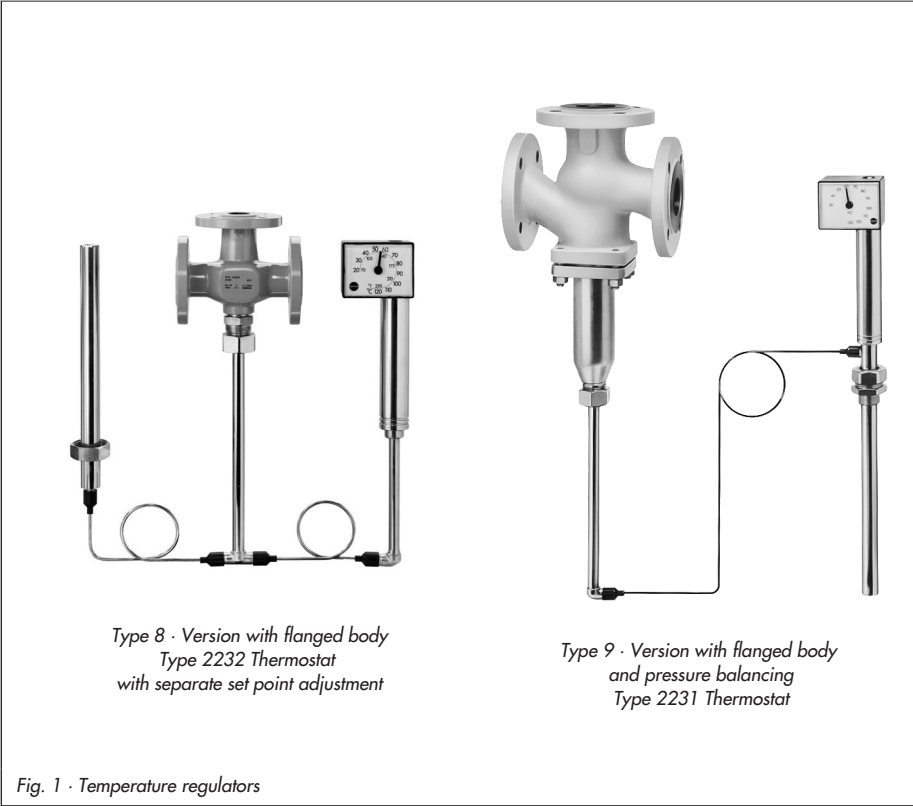

*Type 8 · Version with flanged body  
Type 2232 Thermostat  
with separate set point adjustment*

*Type 9 · Version with flanged body  
and pressure balancing  
Type 2231 Thermostat*

*Fig. 1 · Temperature regulators*

## **Mounting and Operating Instructions**

**EB 2131/2133 EN**

Edition May 2008



Contents	Page
<b>1</b>	<b>Design and principle of operation . . . . . 4</b>
<b>2</b>	<b>Installation . . . . . 6</b>
2.1	Installing the valve . . . . . 6
2.1.1	Strainer . . . . . 8
2.1.2	Additional installation instructions . . . . . 8
2.2	Installing the thermostat . . . . . 8
2.2.1	Types 2231 and 2232 (bulb sensors) . . . . . 8
2.2.2	Types 2233, 2234 and 2235 (air sensors). . . . . 9
2.2.3	Capillary tube. . . . . 10
2.2.4	Operating element . . . . . 10
<b>3</b>	<b>Operation . . . . . 11</b>
3.1	Start-up and set point adjustment . . . . . 11
3.2	Correcting the set point dial . . . . . 11
<b>4</b>	<b>Mounting additional parts . . . . . 11</b>
4.1	Extension piece . . . . . 11
4.2	Distance piece . . . . . 12
4.3	Double adapter . . . . . 12
<b>5</b>	<b>Maintenance—Replacing parts . . . . . 13</b>
<b>6</b>	<b>Description of the nameplates . . . . . 14</b>
<b>7</b>	<b>Customer inquiries . . . . . 14</b>
<b>8</b>	<b>Dimensions in mm and weights . . . . . 15</b>



### **General safety instructions**

- ▶ *The regulators must be mounted, started up and serviced by fully trained and qualified personnel only, observing the accepted industry codes and practices. Make sure employees or third persons are not exposed to any danger.  
All safety instructions and warnings in these instructions, particularly those concerning installation, start-up and maintenance, must be observed.*
- ▶ *The valves fulfill the requirements of the European Pressure Equipment Directive 97/23/EC. Valves with a CE marking have a declaration of conformity that includes information on the applied conformity assessment procedure. The declaration of conformity can be made available on request.*
- ▶ *For appropriate operation, make sure that the temperature regulator is only used in applications where the operating pressure and temperatures do not exceed the operating values based on the valve sizing data submitted in the order.*
- ▶ *Note that the manufacturer does not assume any responsibility for damage caused by external forces or any other external influences.*
- ▶ *Any hazards which could be caused in the temperature regulator by the process medium or operating pressure are to be prevented by means of appropriate measures.*
- ▶ *Proper shipping and appropriate storage are assumed.*



### **Typetesting**

*The Types 2231 to 2235 Control Thermostats have been typetested together with valves by the German Technical Inspectorate (TÜV) in accordance with DIN 3440.*

*Register number is available on request.*

## 1 Design and principle of operation

The temperature regulators consist of a valve, a thermostat and a capillary tube.

The valve comprises the body containing the two seats and plugs as well as the plug stem. Depending on the application of the regulator, different thermostats are attached to the valve.

The thermostat consists of a temperature sensor, a set point adjustment, a capillary tube and an operating element.

The temperature regulators operate according to the liquid expansion principle. The temperature sensor (16) is filled with an expansion liquid. The temperature-dependent change in volume of this liquid causes the double plug (3) to move via the capillary tube (10) and the operating element (8), which is connected to the valve with a coupling nut (7). For example, when the temperature at the sensor (16) rises, the liquid contained in the sensor expands and causes the operating element pin to move upwards. This movement is transmitted to the plug stem (5). As a result, the double plug (3) in the valve body is pushed upwards against the force of the spring (5.1). The plug reduces the inflow at port **B** at the upper seat (2) and increases the inflow at port **A** at the lower seat (mixing valve).

The Type 8 Temperature Regulator is equipped with an unbalanced valve. Type 9 is balanced by a metal bellows (4.1) in valve sizes DN 32 and larger.

The pressure at port **A** is applied to the bottom side of the double plug and transmit-

ted onto the inside of the metal bellows base through the plug stem guide.

The pressure at port **B** is applied to the top of the double plug and transmitted to the outside of the metal bellows base through a hole in the plug stem (5). As a result, the forces acting on the valve plug are balanced, thus balancing the valve as well. Consequently, pressure fluctuations in the process medium do not affect the position of the valve plug.

When used as a mixing valve, port **B** closes when the temperature rises. In diverting valves, port **A** closes when the temperature rises. The set point is adjusted by turning the key (11), which causes a spindle to move the piston (15) up or down. The resulting change in volume in the sensor (16) causes the valve plug to travel in accordance with the adjusted set point within a higher or lower temperature range measured by the sensor.

Valve	Control thermostat
1 Valve body	7 Coupling nut
2 Seat	8 Operating element
3 Plug	9 Pin of operating element
4 Bottom section	10 Capillary tube
4.1 Balancing bellows	11 Set point adjustment key
4.2 Venting plug (DN 65 and larger)	12 Set point dial
5 Plug stem	13 Coupling nut
5.1 Spring	14 Double nipple
6 Threaded connection for operating element	15 Piston
	16 Temperature sensor

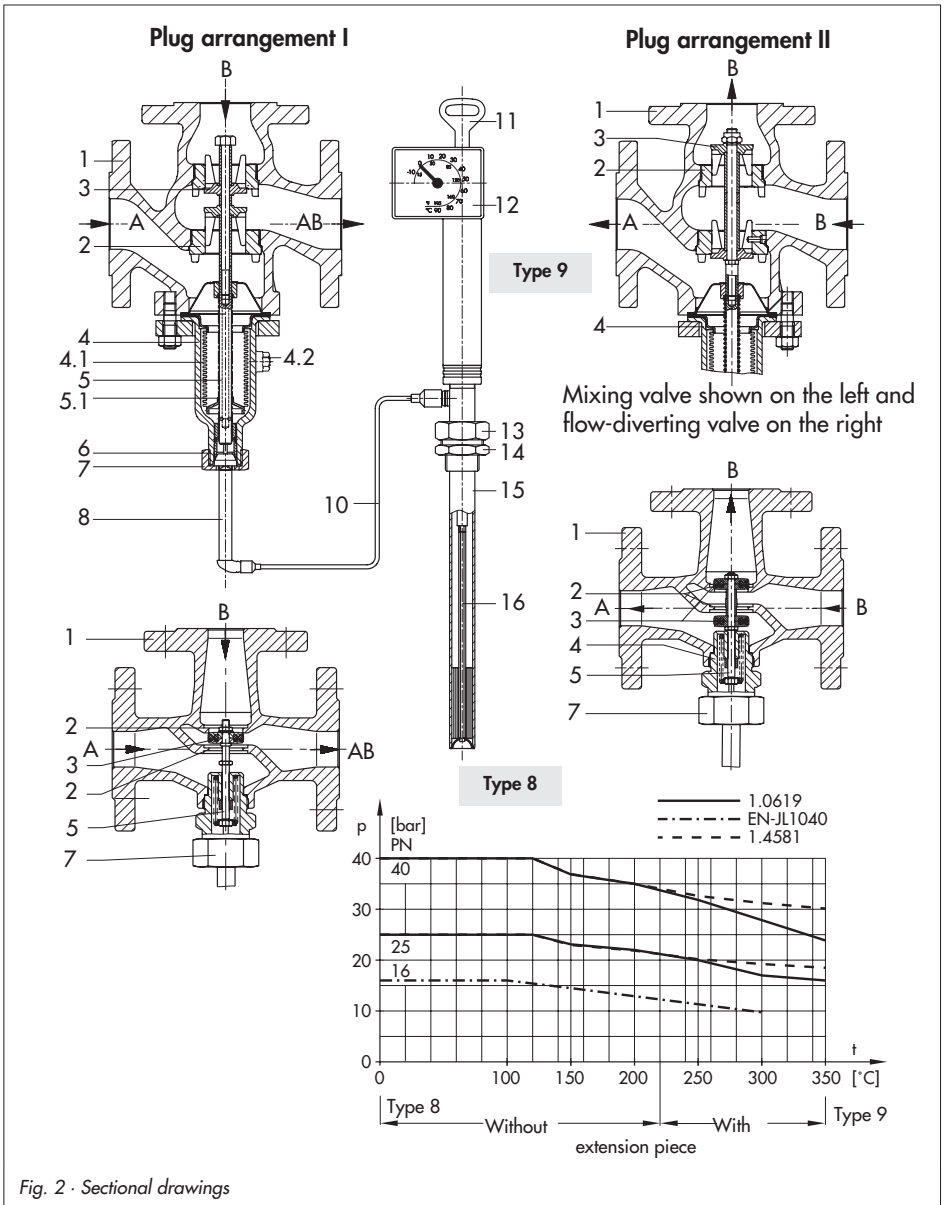

Fig. 2 - Sectional drawings

## 2 Installation

If the manufacturer of the unit or plant has issued specific installation instructions, make sure they are observed.

If necessary, order these instructions from the unit/plant manufacturer.

### 2.1 Installing the valve

Choose a place of installation that allows you to freely access the regulator even after the entire plant has been completed.

**Note!**

*Flush the pipeline thoroughly before installing the temperature regulator.*

Install a strainer (section 2.1.1) upstream of the regulator to prevent that any sealing parts, welding spatter and other impurities carried along by the process medium impair the proper functioning of the valve, above all the tight shut-off.

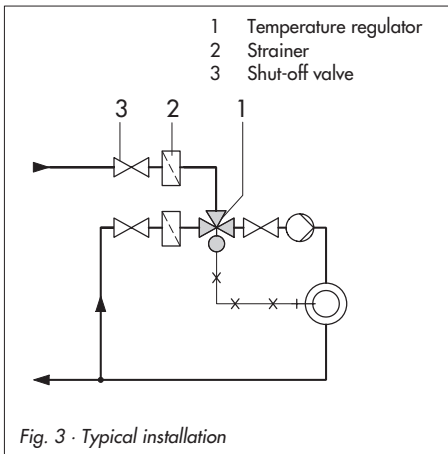

Fig. 3 · Typical installation

When used as a mixing valve, we recommend to install a strainer and shut-off valve upstream of each inlet flange.

**Caution!**

*Install the valve in a horizontal pipeline with the operating element connection suspended downward.*

*Make sure the valve is mounted free of stress and not exposed to excessive vibration (typical installations Fig. 3 and Fig. 4).*

If necessary, support the piping near the connections. When regulating steam, install upstream steam pipes with a slight upward slope and downstream steam pipes with a slight downward slope to prevent steam collection.

**Note!**

*Do not install the temperature regulator outdoors or in rooms subject to frost.*

*If such a location cannot be avoided, the regulator must be protected against frost, unless the process medium is hot water.*

*You can either heat the regulator or remove it from the plant and completely drain the residual water.*



**Caution!**

*Never open the shut-off valves in the plant before the thermostat has been mounted on the valve!*

*The body connection is not sealed tightly until the thermostat has been attached.*

**Plug arrangement I for mixing service**

Port B closes and A opens as the temperature rises

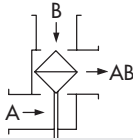

**Plug arrangement II for diverting service**

Port A closes and B opens as the temperature rises

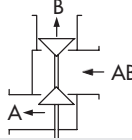

**Heating**

**Mixing valve**

in flow pipe

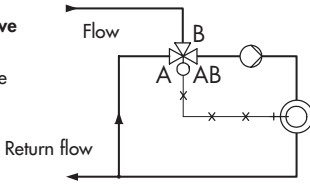

in return flow pipe

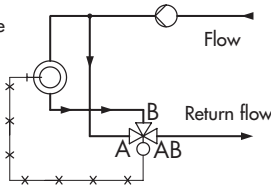

**Diverting valve**

in flow pipe

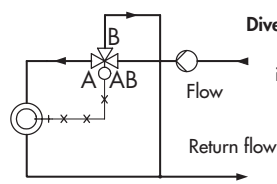

Return flow

in return flow pipe

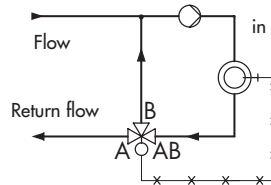

**Cooling**

**Mixing valve**

in flow pipe

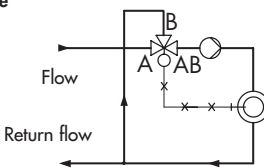

in return flow pipe

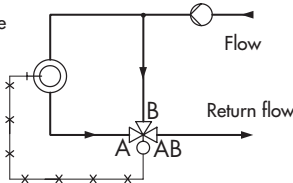

**Diverting valve**

in flow pipe

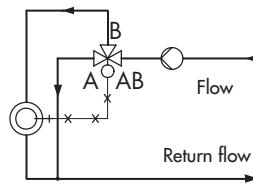

Return flow

in return flow pipe

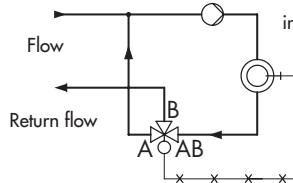

Fig. 4 · Arrangement of temperature regulators

### 2.1.1 Strainer

Install the strainer upstream of the temperature regulator. The direction of flow must correspond to the direction indicated by the arrow on the body.

The filter element must be suspended downwards. Remember to leave enough space to remove it.

### 2.1.2 Additional installation instructions

We recommend to install hand-operated shut-off valves both upstream of the strainer and downstream of the regulator. This allows the plant to be shut down for cleaning or maintenance routines, or when the plant is not operated for extended periods.

To check the adjusted set point, we recommend to install a thermometer near the sensor.

## 2.2 Installing the thermostat

### 2.2.1 Types 2231 and 2232 (bulb sensors)

Bulb sensors are used to measure the temperature of liquids. They are designed for installation in pipelines, heat exchangers, boilers, baths, tanks, etc.

**Note!**

*The entire length of the sensor must be immersed in the process medium. Observe the permissible mounting position as illustrated in Fig. 5.*

When choosing a place of installation, make sure the sensor is installed as close as possible to the heat source, but avoid that the sensor is exposed to overheating. When mounted in a boiler, it is advisable to install the sensor in the upper third.

When mounted in a counterflow heat exchanger, the sensor is best installed in a pipe elbow, directly behind the pipe end socket piece.

In plants with only temporary heat consumption, a circulating pipe is to be provided when the regulator is attached to a counterflow heat exchanger. This ensures that the sensor can always respond to temperature changes in the counterflow heat exchanger, even when no water is tapped.

1. Weld on a female-threaded pipe sleeve (socket-weld design) of approx. 40 mm in length at the place of installation (also applies when thermowell is used).

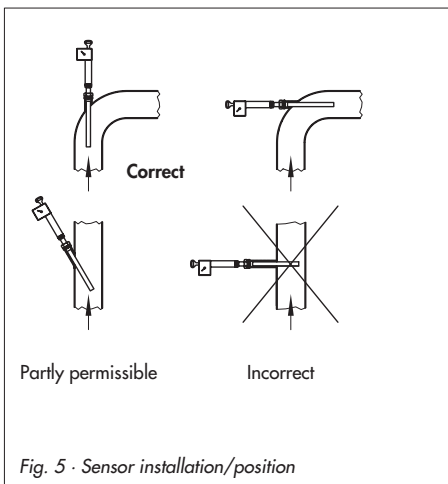

Fig. 5 · Sensor installation/position



- Remove the double nipple (14) of the thermowell (if used) from the sensor (16) and seal it in the welded sleeve.
- Adjust the highest possible set point on the set point dial (12) using the key (11).
- Insert the sensor with the associated seal into the double nipple or thermowell. Secure it with the coupling nut (13). The entire length of the temperature sensor (16) or thermowell must be immersed in the process medium.

### Thermowell:

When a thermowell is used, we recommend to fill the free space between sensor and thermowell with oil or, when installed horizontally, with grease or any other heat transfer medium to avoid delays during heat transmission (remember the thermal expansion of the filling medium; do not fill free space completely or slightly loosen sensor nut for pressure compensation).

### Note!

To avoid damage caused by corrosion, make sure on installing the sensor or thermowell that only the same kind of materials are used together.

For example, do not use a sensor or thermowell made of non-ferrous metal in a stainless steel heat exchanger.

In this case, the sensor should be used together with a stainless steel thermowell.

## 2.2.2 Types 2233, 2234 and 2235 (air sensors)

Types 2233 and 2234 are designed for installation in air heaters, air ducts, drying cabinets, etc. The sensor is installed in the respective object and secured with a special flange (accessories). The entire length of the sensor must be immersed in the air flow to be regulated.

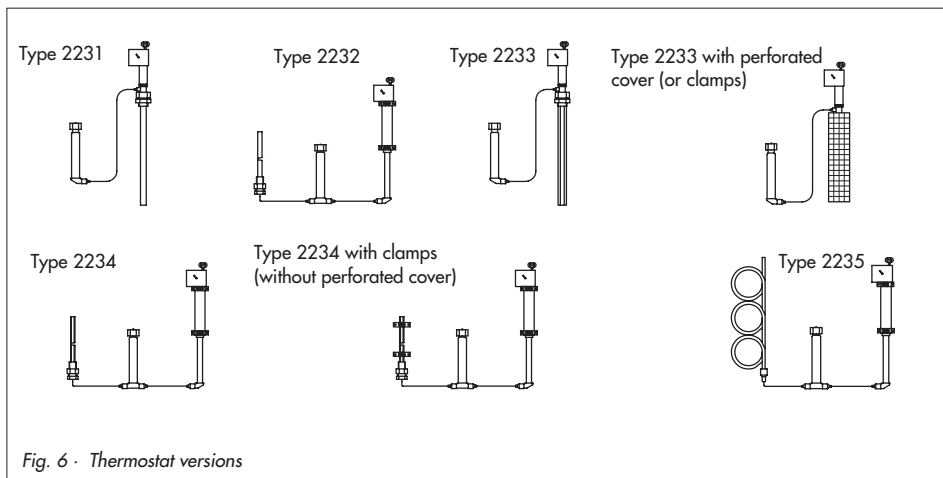

Fig. 6 - Thermostat versions

For Type 2234, install the set point adjustment in an easily accessible location. Avoid locations with considerable ambient temperature fluctuations.

**Type 2233 with perforated cover** is suitable for installation in manufacturing facilities, living spaces, baths, etc. The sensor is protected by a perforated cover and needs to be installed in a suitable location, if possible in the middle of the wall.

**Type 2234 with clamps** (or perforated cover) is suitable for installation in drying chambers, dryers, air heaters, incubators, etc. In case of forced air circulation, the sensor needs to be installed near the supply air inlet. Make sure the set point adjustment is installed outside the room to be controlled in an easily accessible location. Avoid locations with considerable temperature fluctuations.

**Type 2235** is equipped with a temperature sensor to be adjusted on site. This allows you to measure almost all temperature layers. Make sure the set point adjustment for this type is installed outside the room to be controlled in an easily accessible location and where no temperature fluctuations may occur

When regulating the temperature in greenhouses, make sure that the thermostat and set point adjuster are not exposed to direct sunlight.

When the temperature regulating system is shut down during the summer, adjust a high set point to protect the thermostat.

### 2.2.3 Capillary tube

Install the capillary tube (10) without bending or twisting it. Avoid considerable temperature fluctuations along the entire length of the tube.

---

#### **Note!**

*Do not damage or shorten the capillary tube! Roll up excess tube to form a ring. The minimum permissible bending radius is 50 mm.*

---

### 2.2.4 Operating element

Attach the operating element (8) to the valve body using the coupling nut (7). If necessary, use the key (11) to adjust the highest possible set point, causing the operating element pin (9) to retract.

## 3 Operation

### 3.1 Start-up and set point adjustment

Fill the plant **slowly** with the process medium.

#### **Caution!**

*Do not start up temperature regulators until the valve and control thermostat have been assembled together.*

#### **Set point adjustment**

- ▶ Only use the key (11) to adjust the desired temperature set point according to the set point dial (12).
- ▶ Slowly open the hand-operated shut-off valves in the plant.
- ▶ When installing Type 9, briefly undo the venting plug (4.2) and retighten it as soon as process medium escapes.
- ▶ Check the adjusted set point temperature at the thermometer installed near the temperature sensor (see section 2.1.2). Slowly turning the key clockwise increases the temperature; turning counterclockwise reduces it.

#### **Note!**

*Higher set point temperatures can be adjusted in any increments. However, to lower the set point temperature, proceed in steps of 10 to 20 °C.*

*When doing so, wait each time for the process medium to cool down accordingly. Watch the thermometer.*

### 3.2 Correcting the set point dial

Due to specific local conditions, it is possible that the temperature adjusted at the set point dial does not match the temperature measured at the reference thermometer. If this is the case, proceed as follows:

- ▶ Remove the screw marked as readjustment screw on the back of the dial housing.
- ▶ Turn the entire dial housing until the dial shows the same temperature as the reference thermometer.
- ▶ Turn the housing clockwise to increase the set point, and counterclockwise to reduce it (viewed from the front with the dial housing on top).  
A 360° turn corresponds to a set point change of approx. 1.5 °C.

## 4 Mounting additional parts

### 4.1 Extension piece

An extension piece is installed between valve and thermostat to protect the operating element against high temperatures. The extension piece is required for temperatures from 220 °C to max. 350 °C. In case of cast iron (EN-JL1040), it is required up to 300 °C.

The installation of an extension piece on Type 8 Regulators does not permit a higher permissible medium temperature (150 °C).



**Caution!**

When installing the extension piece at a later stage, make sure the relevant section of the pipeline is depressurized and, depending on the medium, also drained. For high medium temperatures, allow the section of the pipeline to cool down to ambient temperature before you start.

1. Adjust the highest possible temperature set point, causing the operating element pin to retract from the plug stem of the valve.
2. Unscrew the operating element.
3. Screw extension piece onto the valve body. Remount the operating element.
4. Adjust the set point as described in section 3.1.

## 4.2 Distance piece

A distance piece is installed between the operating element and valve to protect the operating element from pressures above 16 bar.

Version 1: The spindle (2) is fitted with O-rings which seals the operating element against the process medium.

Version 2: A metal bellows is used as a sealing element.

To install, proceed as described in section 4.1.

## 4.3 Double adapter

The double adapter enables you to connect a further thermostat to achieve additional temperature regulation. See instructions in section 4.1 for installation at a later stage.

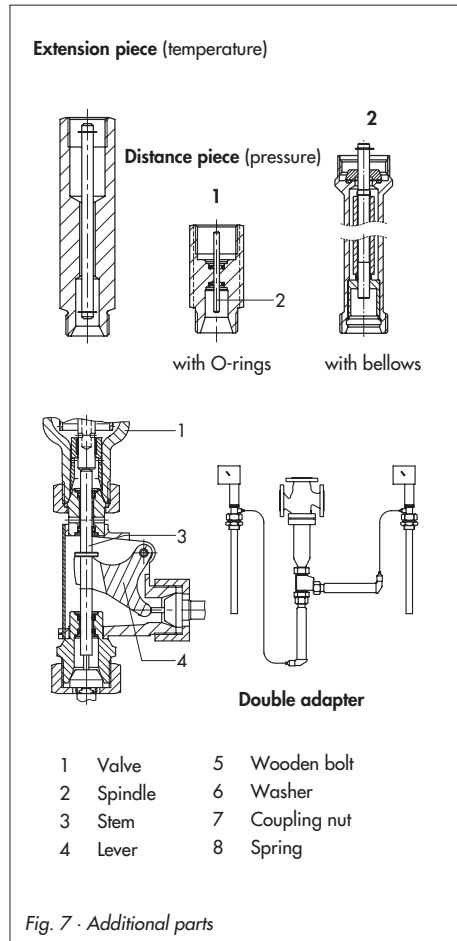

Fig. 7 · Additional parts

## 5 Maintenance—Replacing parts

If the temperature exceeds the value adjusted at the temperature sensor, possible causes include:

- ▶ Valve seat and plug are dirty.
- ▶ Seat and plug leak due to natural wear.
- ▶ The thermostat is defective due to excessive temperatures.

3. Unscrew the valve flange together with the bottom section (4) from the valve body and pull both downwards.
4. Clean the seat and plug and, if necessary, replace them.



### **Caution!**

*Before assembling or disassembling the valve or exchanging a thermostat installed without thermowell, first relieve the corresponding plant section of pressure and, depending on the process medium, drain it as well. Let the plant section cool down to reach ambient temperature, if necessary.*

---

### **Recommended action**

1. If the thermostat is defective, replace it with a new one.  
If the thermostat is not defective, adjust the highest possible temperature set point, causing the operating element pin (9) to retract from the plug stem of the valve.
  2. Remove the coupling nut and operating element.
- 



### **Caution!**

*Any liquid still in the valve body may escape.*

---

## 6 Description of the nameplates

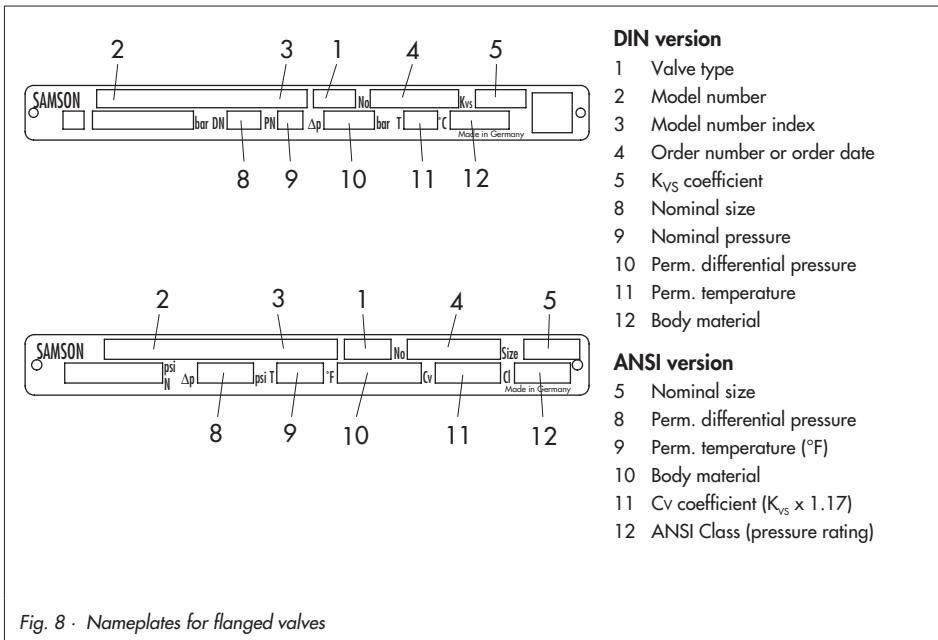

Fig. 8 · Nameplates for flanged valves

## 7 Customer inquiries

Should you have any inquiries regarding temperature regulators, please submit the following details:

- ▶ Type and nominal size
- ▶ Order and model numbers
- ▶ Upstream and downstream pressures
- ▶ Temperature and medium
- ▶ Min. and max. flow rates
- ▶ Has a strainer been installed?
- ▶ Installation drawing

## 8 Dimensions in mm and weights

Nominal size	DN	15	20	25	32	40	50	65	80	100	125	150
Length L	Type 2118	130	150	160	180	200	230	-				
Height H2		70	80	85	100	105	120					
Height H1		78			88							
Height H		370			380							
Weight approx. in kg		5	6.5	8	12.5	14.5	17					
Length L	Type 2119	130	150	160	180	200	230	290	310	350	400	480
Height H2 <sup>1)</sup>		70	80	85	100	105	120	130	140	150	200	210
Height H1 <sup>1)</sup>		235			240		245	320		355	395	500
Height H		525			530		535	610		645	685	790
Weight <sup>2)</sup> approx. in kg		6	7	8.5	15	17	19	32	50	71	On request	

<sup>1)</sup> Change in length takes into account: Distance piece 55 mm or 162/195 mm, extension piece 140 mm

<sup>2)</sup> Applies to PN 16 version · Add 15 % for PN 25/40 version

Thermostat	Type	2231	2231/2232 Size 250	2232	2233	2234	2235
Immersion depth T	mm	290	~980	235	430	460	3460
Weight	kg	3.2	65	4	3.4	3.7	3.6

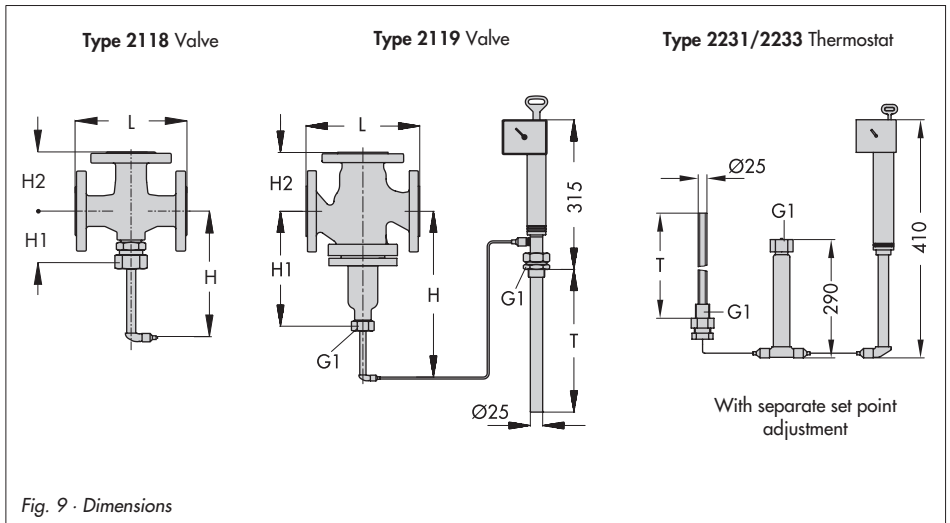



SAMSON AG · MESS- UND REGELTECHNIK  
Weismüllerstraße 3 · 60314 Frankfurt am Main · Germany  
Phone: +49 69 4009-0 · Fax: +49 69 4009-1507  
Internet: <http://www.samson.de>

**EB 2131/2133 EN**

S/Z 2008-06