

Temperature Regulators Type 1 and Type 1u Type 4 and Type 4u

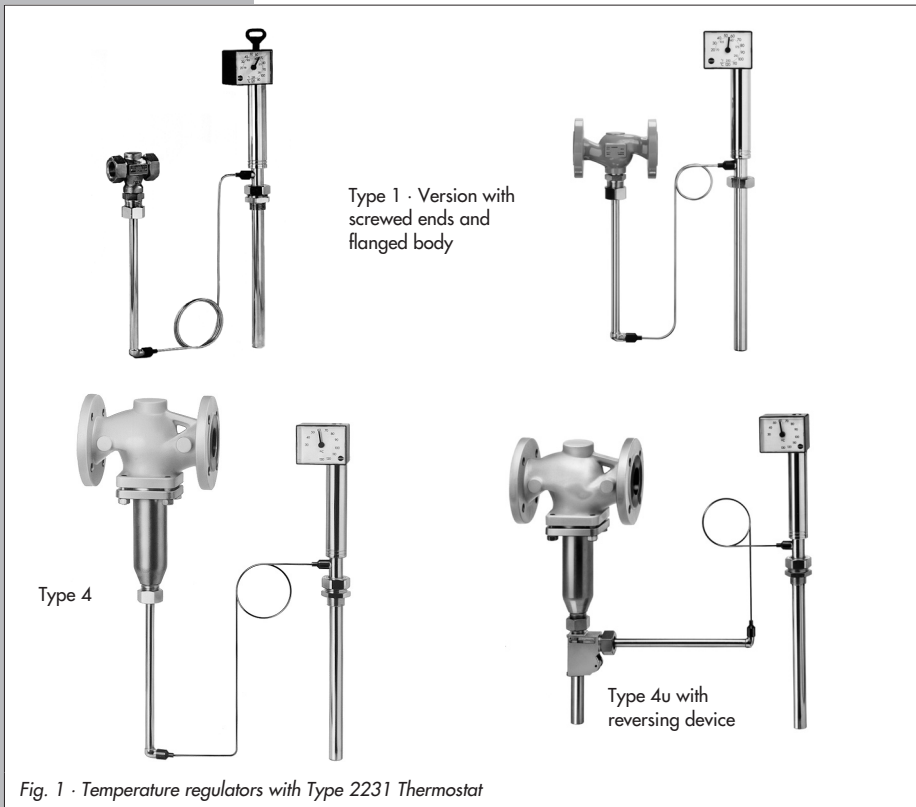

Mounting and Operating Instructions EB 2111/2112/2113 2121/2123 EN



Edition May 2008

Contents	Page
1	Design and principle of operation 4
2	Installation 6
2.1	Installing the valve 6
2.1.1	Strainer 7
2.1.2	Additional installation instructions 7
2.2	Installing the thermostat 7
2.2.1	Types 2231 and 2232 (bulb sensors) 7
2.2.2	Types 2233, 2234 and 2235 (air sensors). 8
2.2.3	Capillary tube 9
2.2.4	Operating element 9
3	Operation 10
3.1	Start-up and set point adjustment 10
3.2	Correcting the set point dial 10
4	Mounting additional parts 10
4.1	Extension piece 10
4.2	Distance piece 11
4.3	Double adapter 12
4.4	Reversing device in Type 4u 12
5	Maintenance—Replacing parts 13
6	Description of the nameplates 14
7	Customer inquiries 14
8	Dimensions in mm and weights 15



Typetesting

The Types 2231 to 2235 Control Thermostats have been typetested together with valves by the German Technical Inspectorate (TÜV) in accordance with DIN EN 14597.

Register number is available on request.



General safety instructions

- ▶ *The regulators must be mounted, started up and serviced by fully trained and qualified personnel only, observing the accepted industry codes and practices. Make sure employees or third persons are not exposed to any danger.
All safety instructions and warnings in these instructions, particularly those concerning installation, start-up and maintenance, must be observed.*
- ▶ *The valves fulfill the requirements of the European Pressure Equipment Directive 97/23/EC. Valves with a CE marking have a declaration of conformity that includes information on the applied conformity assessment procedure. The declaration of conformity can be made available on request.*
- ▶ *For appropriate operation, make sure that the temperature regulator is only used in applications where the operating pressure and temperatures do not exceed the operating values based on the valve sizing data submitted in the order.*
- ▶ *Note that the manufacturer does not assume any responsibility for damage caused by external forces or any other external influences.*
- ▶ *Any hazards which could be caused in the temperature regulator by the process medium or operating pressure are to be prevented by means of appropriate measures.*
- ▶ *Proper shipping and appropriate storage are assumed.*

Note!

*The non-electric actuators and valves do not have their own potential ignition source according to the ignition risk assessment stipulated in EN 13463-1: 2001, section 5.2, even in the rare incident of an operating fault. Therefore, they **do not** fall within the scope of Directive 94/9/EC.*

For connection to the equipotential bonding system, observe the requirements specified in EN 60079-14: 1977 (VDE 0165 Part 1), section 6.3.

1 Design and principle of operation

The temperature regulators comprise a valve, thermostat and capillary tube.

The valve consists of the body with a seat, plug and plug stem. Depending on the application, different thermostats can be attached to the valve. The thermostat comprises a temperature sensor, set point adjuster, capillary tube and operating element.

The temperature regulators operate according to the liquid expansion principle. When, for example, the temperature at the temperature sensor (19) increases, the liquid contained in the sensor expands, pushing the pin (9) of the operating element upwards by the bellows (10). During this process, the pin pushes the plug stem (5) together with the plug (3) towards the valve seat until - while the temperature at the sensor continues to rise - the valve is fully closed.

The Type 1 Temperature Regulator is equipped with an unbalanced valve.

Type 4, however, has a valve balanced by a bellows (4.1). Here, the upstream pressure is transferred through the hole in the plug stem onto the outer surface of the bellows bottom and the downstream pressure to the inner surface. As a result, the forces acting on the plug are at an equilibrium and the valve is fully balanced. Consequently, any pressure changes in the process medium do not affect the position of the valve plug.

The reverse-acting Types 1u and 4u Temperature Regulators are used in plants intended to be cooled. Their principle of operation is reverse to that of the standard version, i.e. the valve opens when the temperature at the

sensor rises. To achieve this, the valve plug is located above the valve seat in Type 1u and a reversing device is installed between the valve and the operating element in Type 4u.

Table 1 · Type 1 and Type 4 Temperature Regulators

Temperature regulator	Valve	Thermostat
1	2111	2231 to 2235
1u	2121	
4	2114	
4u	2114 with reversing device	

The set point can be adjusted using a key (12). By turning the key, a spindle moves the piston (18) up or down, causing the volume of the liquid contained in the sensor (19) to change. As a result, the valve plug travels according to the adjusted set point within a higher or lower temperature range measured by the sensor.

Valve	Control thermostat
1 Valve body	7 Coupling nut
2 Seat	8 Operating element
3 Plug	9 Pin of operating element
4 Bottom section	10 Positioning bellows
4.1 Balancing bellows	11 Capillary tube
4.2 Venting plug (DN 65 and larger)	12 Set point adjustment key
5 Plug stem	13 Set point dial
5.1 Spring	14 Spindle
6 Threaded connection for operating element	15 Excess temperature protection
	16 Coupling nut
	17 Double nipple
	18 Piston
	19 Temperature sensor

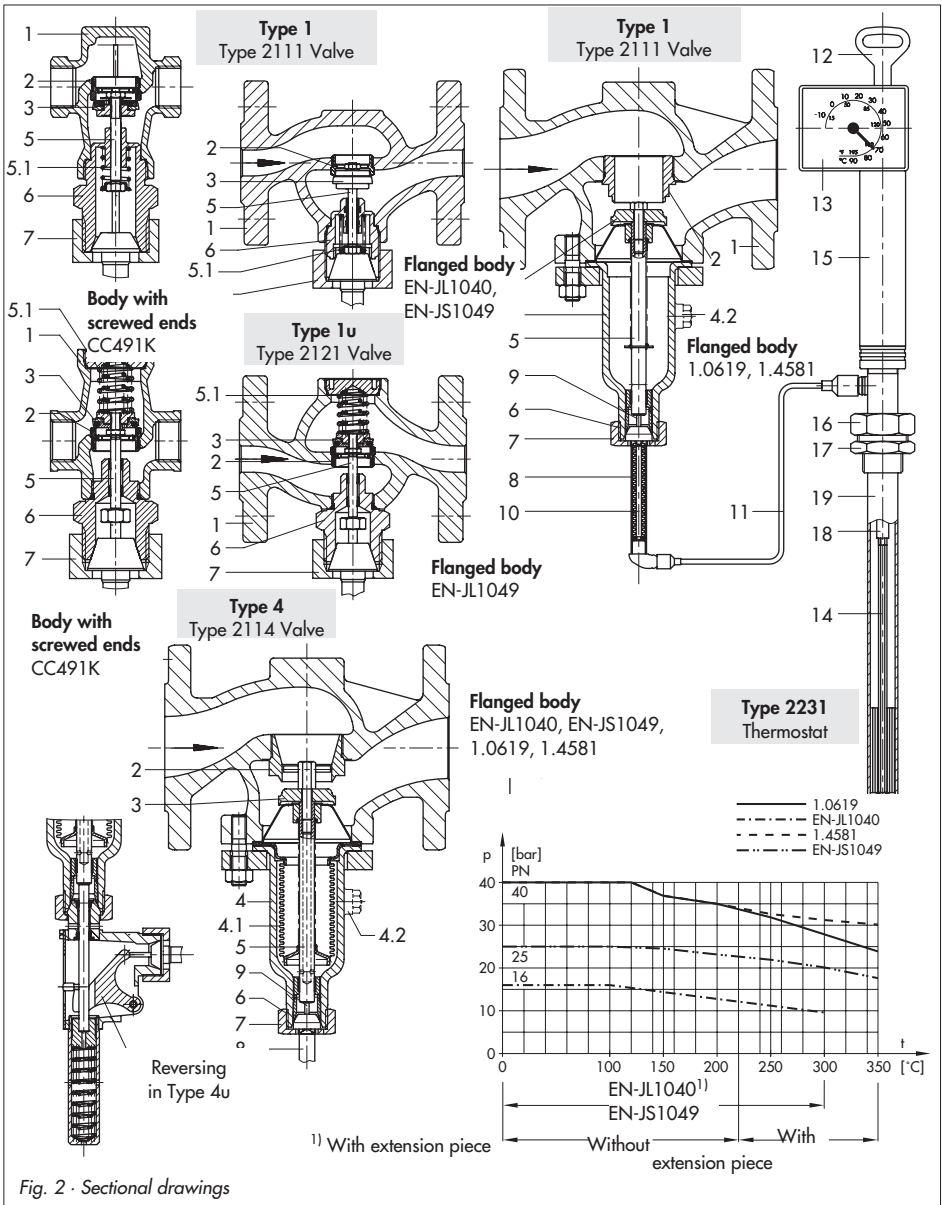

Fig. 2 - Sectional drawings

2 Installation

If the manufacturer of the unit or plant has issued specific installation instructions, make sure they are observed.

If necessary, order these instructions from the unit/plant manufacturer.

2.1 Installing the valve

Choose a place of installation that allows you to freely access the regulator even after the entire plant has been completed.

Note!

Do not install the temperature regulators between a pressure reducing valve and its control line connection!

Flush the pipeline thoroughly before installing the temperature regulator.

Install a strainer (section 2.1.1) upstream of the regulator to prevent that any sealing parts, welding spatter and other impurities

carried along by the process medium impair the proper functioning of the valve, above all the tight shut-off.

Note!

Install the valve in a horizontal pipeline with the operating element connection suspended downwards.

With Type 1u and Type 4u (only up to DN 80), the valve can also be installed with the operating element pointing upwards.

The direction of flow must correspond with the arrow on the body.

The valve body must be installed free of stress. If necessary, support the piping near the connections.

When regulating steam, install upstream steam pipes with a slight upward slope and downstream steam pipes with a slight downward slope to prevent condensate collection.

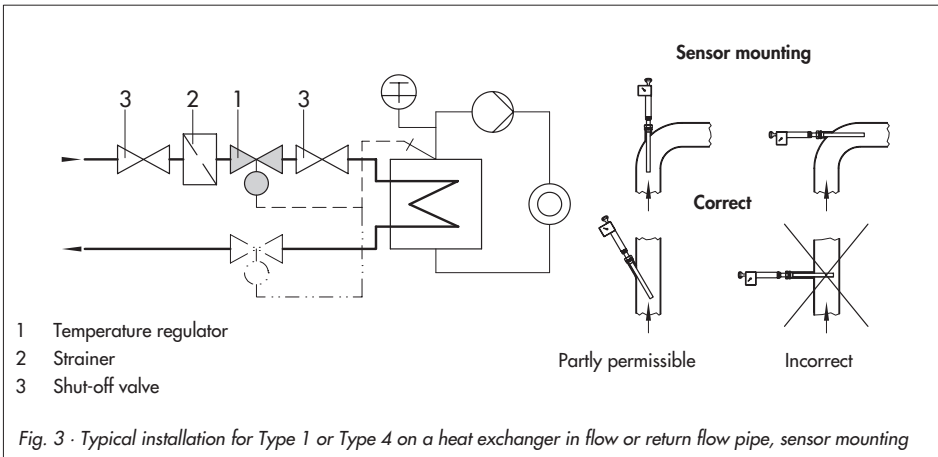

Fig. 3 · Typical installation for Type 1 or Type 4 on a heat exchanger in flow or return flow pipe, sensor mounting

Note!

Do not install the temperature regulator outdoors or in rooms subject to frost.

If such a location cannot be avoided, the regulator must be protected against frost, unless the process medium is hot water.

You can either heat the regulator or remove it from the plant and completely drain the residual water.

**Caution!**

Do not open the shut-off valves in the plant before the thermostat has been mounted on the valve!

The body connection is not sealed tightly until the thermostat has been attached.

2.1.1 Strainer

Install the strainer upstream of the temperature regulator. The direction of flow must correspond to the direction indicated by the arrow on the body.

The filter element must be suspended downwards. Remember to leave enough space to remove it.

2.1.2 Additional installation instructions

We recommend to install hand-operated shut-off valves both upstream of the strainer and downstream of the regulator. This allows the plant to be shut down for cleaning or maintenance routines, or when the plant is not operated for extended periods.

To check the adjusted set point, we recommend to install a thermometer near the sensor.

2.2 Installing the thermostat

2.2.1 Types 2231 and 2232 (bulb sensors)

Bulb sensors are used to measure the temperature of liquids. They are designed for installation in pipelines, heat exchangers, boilers, baths, tanks, etc.

Note!

The entire length of the sensor must be immersed in the process medium. Observe the permissible mounting position as illustrated in Fig. 3.

When choosing a place of installation, make sure the sensor is installed as close as possible to the heat source, but avoid that the sensor is exposed to overheating. When mounted in a boiler, it is advisable to install the sensor in the upper third.

When mounted in a counterflow heat exchanger, the sensor is best installed in a pipe elbow, directly behind the pipe end socket piece.

In plants with only temporary heat consumption, a circulating pipe is to be provided when the regulator is attached to a counterflow heat exchanger. This ensures that the sensor can always respond to temperature changes in the counterflow heat exchanger, even when no water is tapped.

1. Weld on a female-thread pipe sleeve (socket-weld design) of approx. 40 mm

- in length at the place of installation (also applies when thermowell is used).
- Remove the double nipple (17) of the thermowell (if used) from the sensor (19) and seal it in the welded sleeve.
 - Adjust the highest possible set point on the set point dial (13) using the key (12).
 - Insert the sensor with the associated seal into the double nipple or thermowell. Secure it with the coupling nut (16). The entire length of the temperature sensor (19) or thermowell must be immersed in the process medium.

Thermowell:

When a thermowell is used, we recommend to fill the free space between sensor and thermowell with oil or, when installed horizontally, with grease or any other heat transfer medium to avoid delays during heat transmission (remember the thermal expansion of the filling medium; do not fill free

space completely or slightly loosen sensor nut for pressure compensation).

Note!

To avoid damage caused by corrosion, make sure on installing the sensor or thermowell that only the same kind of materials are used together.

For example, do not use a sensor or thermowell made of non-ferrous metal in a stainless steel heat exchanger.

In this case, the sensor should be used together with a stainless steel thermowell.

2.2.2 Types 2233, 2234 and 2235 (air sensors)

Types 2233 and 2234 are designed for installation in air heaters, air ducts, drying cabinets, etc. The sensor is installed in the respective object and secured with a special flange (accessories).

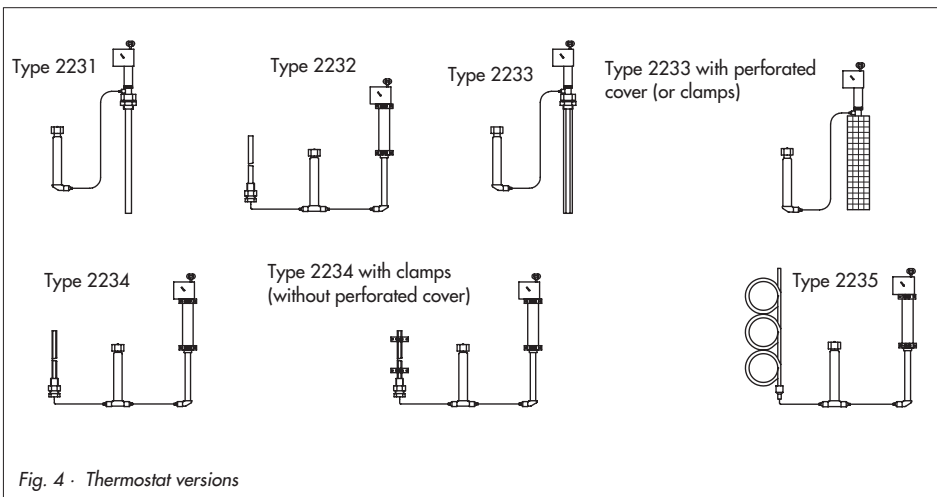

Fig. 4 · Thermostat versions

The entire length of the sensor must be immersed in the air flow to be regulated.

For Type 2234, install the set point adjustment in an easily accessible location. Avoid locations with considerable ambient temperature fluctuations.

Type 2233 with perforated cover is suitable for installation in manufacturing facilities, living spaces, baths, etc. The sensor is protected by a perforated cover and needs to be installed in a suitable location, if possible in the middle of the wall.

Type 2234 with clamps (or perforated cover) is suitable for installation in drying chambers, dryers, air heaters, incubators, etc. In case of forced air circulation, the sensor needs to be installed near the supply air inlet. Make sure the set point adjustment is installed outside the room to be controlled in an easily accessible location. Avoid locations with considerable temperature fluctuations.

Type 2235 is equipped with a temperature sensor to be adjusted on site. This allows you to measure almost all temperature layers. Make sure the set point adjustment for this type is installed outside the room to be controlled in an easily accessible location and where no temperature fluctuations may occur.

When regulating the temperature in greenhouses, make sure that the thermostat and set point adjuster are not exposed to direct sunlight.

When the temperature regulating system is shut down during the summer, adjust a high set point to protect the thermostat.

2.2.3 Capillary tube

Install the capillary tube (11) without bending or twisting it. Avoid considerable temperature fluctuations along the entire length of the tube.

Note!

Do not damage or shorten the capillary tube! Roll up excess tube to form a ring. The minimum permissible bending radius is 50 mm.

2.2.4 Operating element

Attach the operating element (8) to the valve body using the coupling nut (7). If necessary, use the key (12) to adjust the highest possible set point, causing the operating element pin (9) to retract.

3 Operation

3.1 Start-up and set point adjustment

Fill the plant **slowly** with the process medium.

Caution!

Do not start up temperature regulators until the valve and control thermostat have been assembled together.

Set point adjustment

- ▶ Only use the key (12) to adjust the desired temperature set point according to the set point dial (13).
- ▶ Slowly open the hand-operated shut-off valve downstream of the valve and then the shut-off valve upstream of the valve.
- ▶ When installing Type 4 and 4u, briefly undo the venting plug (4.2) and retighten it as soon as process medium escapes.
- ▶ Check the adjusted set point temperature at the thermometer installed near the temperature sensor (see section 2.1.2). Slowly turning the key clockwise increases the temperature; turning counterclockwise reduces it.

Note!

Higher set point temperatures can be adjusted in any increments. However, to lower the set point temperature, proceed in steps of 10 to 20 °C.

When doing so, wait each time for the process medium to cool down accordingly. Watch the thermometer.

3.2 Correcting the set point dial

Due to specific local conditions, it is possible that the temperature adjusted at the set point dial does not match the temperature measured at the reference thermometer. If this is the case, proceed as follows:

- ▶ Remove the screw marked as readjustment screw on the back of the dial housing.
- ▶ Turn the entire dial housing until the dial shows the same temperature as the reference thermometer.
- ▶ Turn the housing clockwise to increase the set point, and counterclockwise to reduce it (viewed from the front with the dial housing on top).
A 360° turn corresponds to a set point change of approx. 1.5 °C.

4 Mounting additional parts

4.1 Extension piece

An extension piece is installed between valve and thermostat to protect the operating element against high temperatures.

For Type 1: DN 15 to DN 50 for 220 °C and higher (only with 1.0619 and 1.4581).

For Type 4: DN 15 to DN 100 for 220 °C and higher; DN 125 to DN 250 for 220 °C and higher already attached to the valve, up to max. 350 °C.



Caution!

When installing the extension piece at a later stage, make sure the relevant section of the pipeline is depressurized and, depending on the medium, also drained. For high medium temperatures, allow the section of the pipeline to cool down to ambient temperature before you start.

1. Adjust the highest possible temperature set point, causing the operating element pin to retract from the plug stem of the valve.
2. Unscrew the operating element.
3. Screw extension piece onto the valve body. Remount the operating element.
4. Adjust the set point as described in section 3.1.

4.2 Distance piece

A distance piece is installed between the operating element and valve to protect the operating element from pressures above 16 bar. In stainless steel versions, it separates the non-ferrous metals of the operating element from the medium in the valve as well as preventing the medium from escaping on changing the thermostat.

Version 1: The spindle (2) is fitted with O-rings which seals the operating element against the process medium.

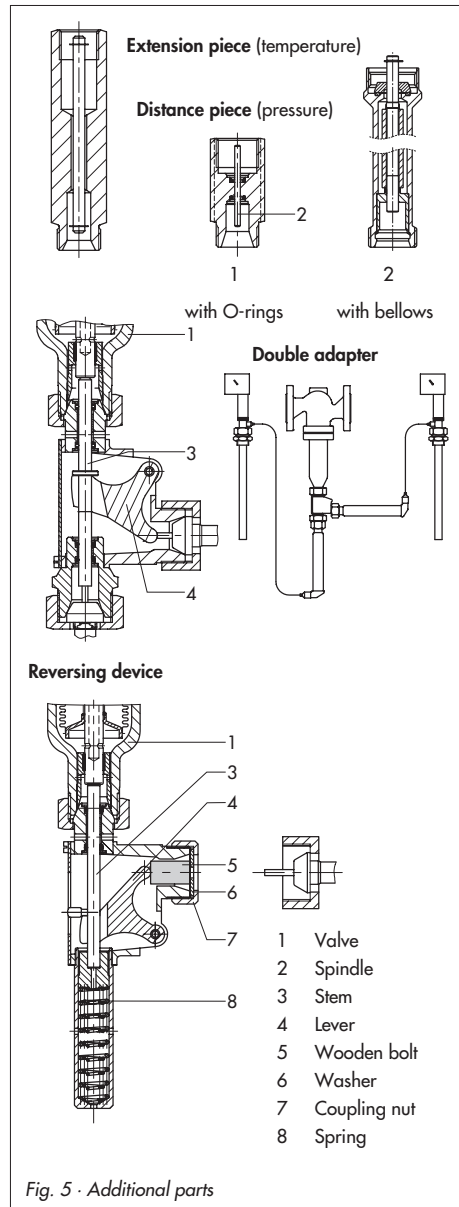

Fig. 5 · Additional parts

Version 2: A metal bellows is used as a sealing element.

To install, proceed as described in section 4.1.

4.3 Double adapter

The double adapter enables you to connect a further thermostat to achieve additional temperature regulation.

See instructions in section 4.1 for installation at a later stage.

4.4 Reversing device in Type 4u

Note!

The reversing device can only be attached to the valve when the stem (3) is fully retracted.

Therefore, the spring (8) of the reversing device is pretensioned upon delivery over the lever (4) using a wooden bolt (5) with a washer (6) and coupling nut (7).

Installation:

1. Screw the pretensioned reversing device to the bottom section of the valve.
2. Due to the device being pretensioned, the coupling nut (7) needs to be **unscrewed carefully**. Remove it from the reversing device together with the wooden bolt and washer.
Keep the parts. You might need them again to pretension the reversing device when reinstalling it after it had to be disassembled.
3. Adjust the highest possible set point, causing the pin of the operating element

to retract. Remount the operating element.

Disassembly:

If at all possible, do not remove the reversing device unless the stem (3) is retracted. Adjust the set point of the attached thermostat to the lowest possible value, so that the pin of the operating element causes the stem (3) to retract via the lever (4).

- ▶ Slowly unscrew the coupling nut at the bottom section of the valve to remove the reversing device from the valve connection.



Caution!

If the reversing device is removed while the stem (3) is extended (valve closed), the coupling nut is loaded with the full spring force.

5 Maintenance—Replacing parts

The temperature regulator is maintenance free. Nevertheless, it is subject to natural wear, particularly at the seat and plug. Depending on the operating conditions, the regulator needs to be checked at regular intervals to avoid possible malfunctions.

If the temperature exceeds the value adjusted at the temperature sensor, possible causes may be:

- ▶ Valve seat and plug are dirty.
- ▶ Seat and plug leak due to natural wear.
- ▶ The thermostat is defective due to excessive temperatures.



Caution!

Before assembling or disassembling the valve or exchanging a thermostat installed without thermowell, first relieve the corresponding plant section of pressure and, depending on the process medium, drain it as well. Let the plant section cool down to reach ambient temperature, if necessary.



Caution!

Any liquid still in the valve body may escape.

3. Unscrew the valve flange together with the bottom section (4) from the valve body and pull both downwards.
4. Clean the seat and plug and, if necessary, replace them.

Recommended action

1. If the thermostat is defective, replace it with a new one.
If the thermostat is not defective, adjust the highest possible temperature set point, causing the operating element pin (9) to retract from the plug stem of the valve.
2. Remove the coupling nut and operating element.

6 Description of the nameplates

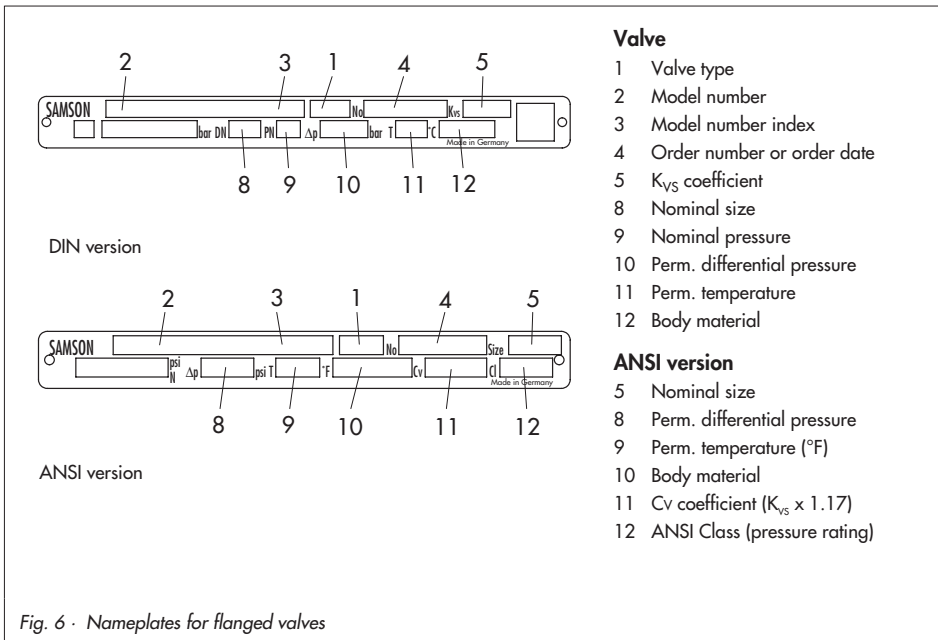

7 Customer inquiries

Should you have any inquiries regarding temperature regulators, please submit the following details:

- ▶ Type and nominal size
- ▶ Order and model numbers
- ▶ Upstream and downstream pressures
- ▶ Temperature and medium
- ▶ Min. and max. flow rates
- ▶ Has a strainer been installed?
- ▶ Installation drawing

8 Dimensions in mm and weights

Type 1	DN	G ½	G ¾	G 1	15	20	25	32	40	50
Length L		65	75	90	130	150	160	180	200	230
H1 ¹⁾	EN-JS1049,	-			82			152		
H1 ¹⁾	EN-JL1040, CC491K	-			372			442		
Weight approx. in kg		0.9	1.0	1.1	4			10 ²⁾		
H1 ¹⁾	1.0619, 1.4581	-			225					
H1 ¹⁾		-			515					
Weight approx. in kg		-			4	4.5	5.5	10	11.5	13.5
Type 1u	DN	G ½	G ¾	G 1	15	20	25	32	40	50
Length L		65	75	90	130	150	160	180	200	230
Height H		350			249			329		
Height H1		60			59			80		
Height H2		46			46			92		
Weight approx. in kg		1	1.3	1.5	4.5	5	6	11	11.5	14

¹⁾ Change in length takes into account: Distance piece 55 mm or 162/195 mm, extension piece 140 mm

²⁾ Applies to PN 16 version · Add 15 % for PN 25/40 version

Types 4 and 4u	DN	15	20	25	32	40	50	65	80	100	125	150	200	250
Length L		130	150	160	180	200	230	290	310	350	400	480	600	730
Height H1 ¹⁾		225						300	355	460	590	730		
Height H ¹⁾		515						590	645	750	880	1020		
Height H* (Type 4u)		515						545	570	675	910	1050		
Weight ²⁾ approx. kg		5	5.5	6.5	13	13.5	16	27	32	40	70	113	255	300

¹⁾ Change in length takes into account: Distance piece 55 mm or 162/195 mm, extension piece 140 mm

²⁾ Applies to PN 16 version · Add 15 % for PN 25/40 version

Thermostat	Type	2231	2231/2232 Size 250	2232	2233	2234	2235
Immersion depth T	mm	290	~980	235	430	460	3460
Weight	kg	3.2	65	4	3.4	3.7	3.6

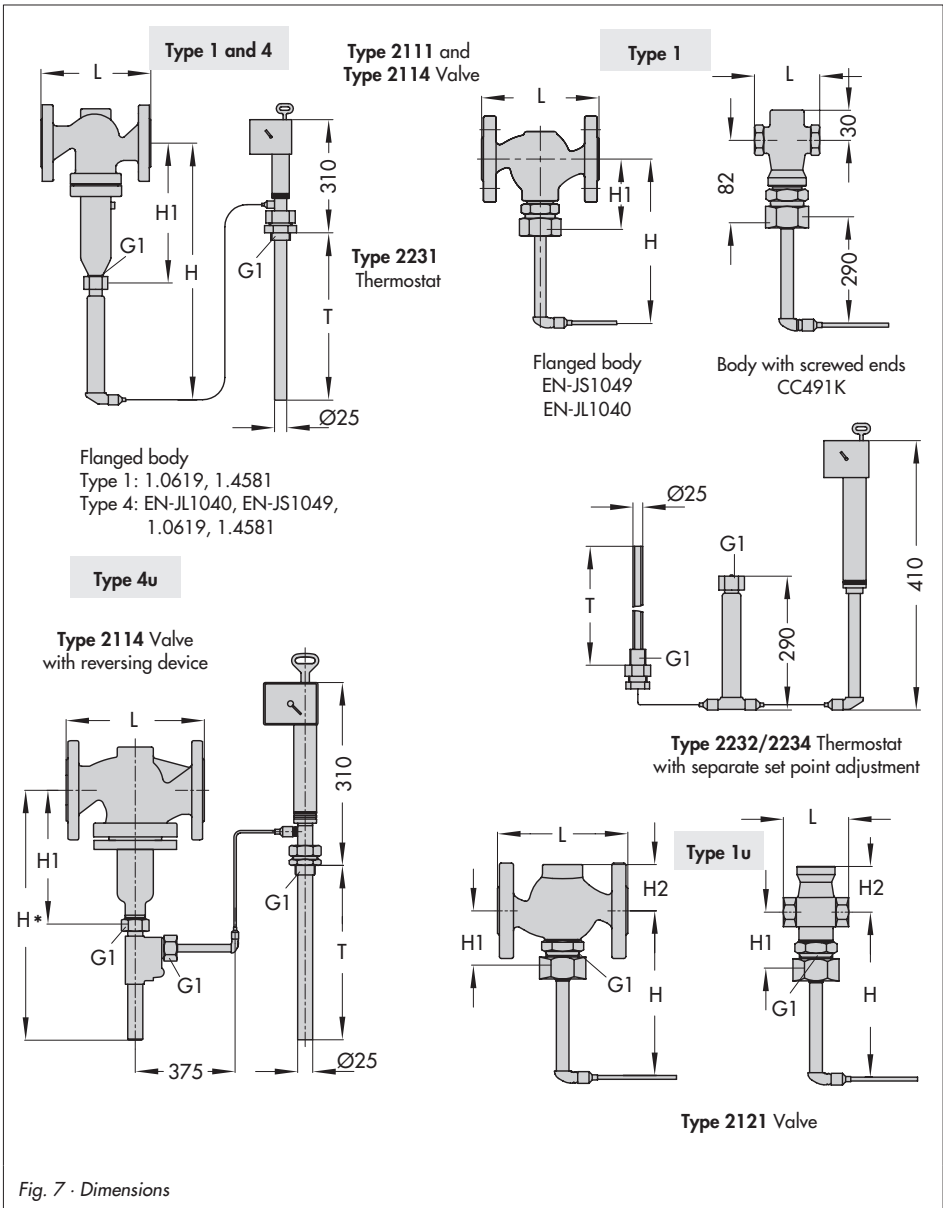



SAMSON AG · MESS- UND REGELTECHNIK
Weismüllerstraße 3 · 60314 Frankfurt · Germany
Phone: +49 69 4009-0 · Fax: +49 69 4009-1507
Internet: <http://www.samson.de>

EB 2111/2112/2113
2121/2123 EN

S/Z 2009-03