

Self-operated Regulators

Universal Excess Pressure Valve Type 41-73



Type 41-73 Excess Pressure Valve

Mounting and Operating Instructions

EB 2517 EN

Edition December 2007



Contents	Page
1	Design and principle of operation 4
2	Installation 4
2.1	Assembly 4
2.2	Mounting position 6
2.3	Control line, condensation chamber and needle valve. 7
2.4	Strainer. 8
2.5	Shut-off valve 8
2.6	Pressure gauge 8
3	Operation 8
3.1	Start-up. 8
3.2	Set point adjustment. 9
3.3	Decommissioning 10
4	Cleaning and maintenance 10
4.1	Replacing the operating diaphragm 10
5	Customer service 12
6	Dimensions 12
7	Nameplates 14
8	Technical data. 15

Definitions of the signal words used in these instructions

CAUTION!

CAUTION indicates a hazardous situation which, if not avoided, may result in minor or moderate injury.

Note:

Supplementary explanations, information and tips

NOTICE

NOTICE indicates a property damage message.



General safety instructions

- ▶ *The regulators must be installed, started up and serviced by fully trained and qualified personnel only, observing the accepted industry codes and practices. Make sure employees or third persons are not exposed to any danger*
All safety instructions and warnings in these instructions, particularly those concerning installation, start-up, and maintenance, must be observed.
- ▶ *The regulator complies with the requirements of the European Pressure Equipment Directive 97/23/EC. The declaration of conformity issued for a valve bearing the CE marking includes information on the applied conformity assessment procedure.*
The declaration of conformity can be provided on request.
- ▶ *For appropriate operation, make sure that the regulator is only used in applications where the operating pressure and temperatures do not exceed the operating values based on the sizing data submitted in the order.*
- ▶ *Note that the manufacturer does not assume any responsibility for damage caused by external forces or any other external factors.*
Any hazards which could be caused in the regulator by the process medium or operating pressure are to be prevented by means of appropriate measures.
- ▶ *Proper shipping and appropriate storage are assumed.*

1 Design and principle of operation

The Type 41-73 Excess Pressure Valve consists of a Type 2417 Opening Valve and a Type 2413 Actuator. The valve and actuator are delivered separately and must be assembled according to the instructions in section 2.1.

The excess pressure valve is used to maintain the pressure upstream of the valve at an adjusted set point.

The process medium to be regulated flows through the valve between the seat (2) and the plug (3) in the direction indicated by the arrow on the body. The position of the valve plug determines the flow rate, and thus the pressure ratio across the valve. The plug stem is sealed by a frictionless metal bellows (5.1).

The upstream pressure p_1 is transmitted through the condensation chamber (18) and the control line (17) to the operating diaphragm (12) where it is converted into a positioning force. For actuator versions with a bellows, the pressure is transmitted to the operating bellows (12.1). The positioning force is used to move the valve plug according to the force of the positioning springs (7). The spring force is adjustable at the set point adjustment (6). Valves with Kvs 2.5 or higher feature a balancing bellows (4). The upstream pressure acts on the outside of the bellows and the downstream pressure on the inside of the bellows. As a result, the forces produced by the upstream and downstream pressures acting on the plug are balanced.

Depending on the valve and actuator used, the regulator can be upgraded to create a millibar excess pressure valve or a safety excess pressure valve.

2 Installation

2.1 Assembly

Valve and actuator can be assembled before or after the valve has been installed in the pipeline. Push the actuator (10) together with the actuator stem (11) through the hole in the bracket (8) onto the spigot of the bellows seal (5.1). Align and secure it with the nuts (9, width across flats SW 17).

For actuators in DN 65 to DN 100 and with a metal bellows, remove the bracket (8) from the valve and unscrew the pillars. Screw the pillars into the actuator flange. Push the actuator onto the valve and secure the pillar at the valve flange using the nuts.

- | | |
|------|--|
| 1 | Valve body |
| 2 | Seat |
| 3 | Plug |
| 4 | Balancing bellows |
| 5 | Plug stem |
| 5.1 | Bellows seal |
| 6 | Set point adjustment |
| 7 | Positioning springs |
| 8 | Bracket |
| 9 | Fastening nuts |
| 10 | Actuator |
| 11 | Actuator stem |
| 12 | Operating diaphragm |
| 12.1 | Operating bellows |
| 13 | Diaphragm plate |
| 14 | Nut |
| 15 | Nuts and bolts |
| 16 | Control line connection (for steam including screw joint with restriction) |
| 17 | Control line to be provided on site (control line kit (accessory) for direct connection to the body) |
| 18 | Condensation chamber |
| 19 | Filler plug |

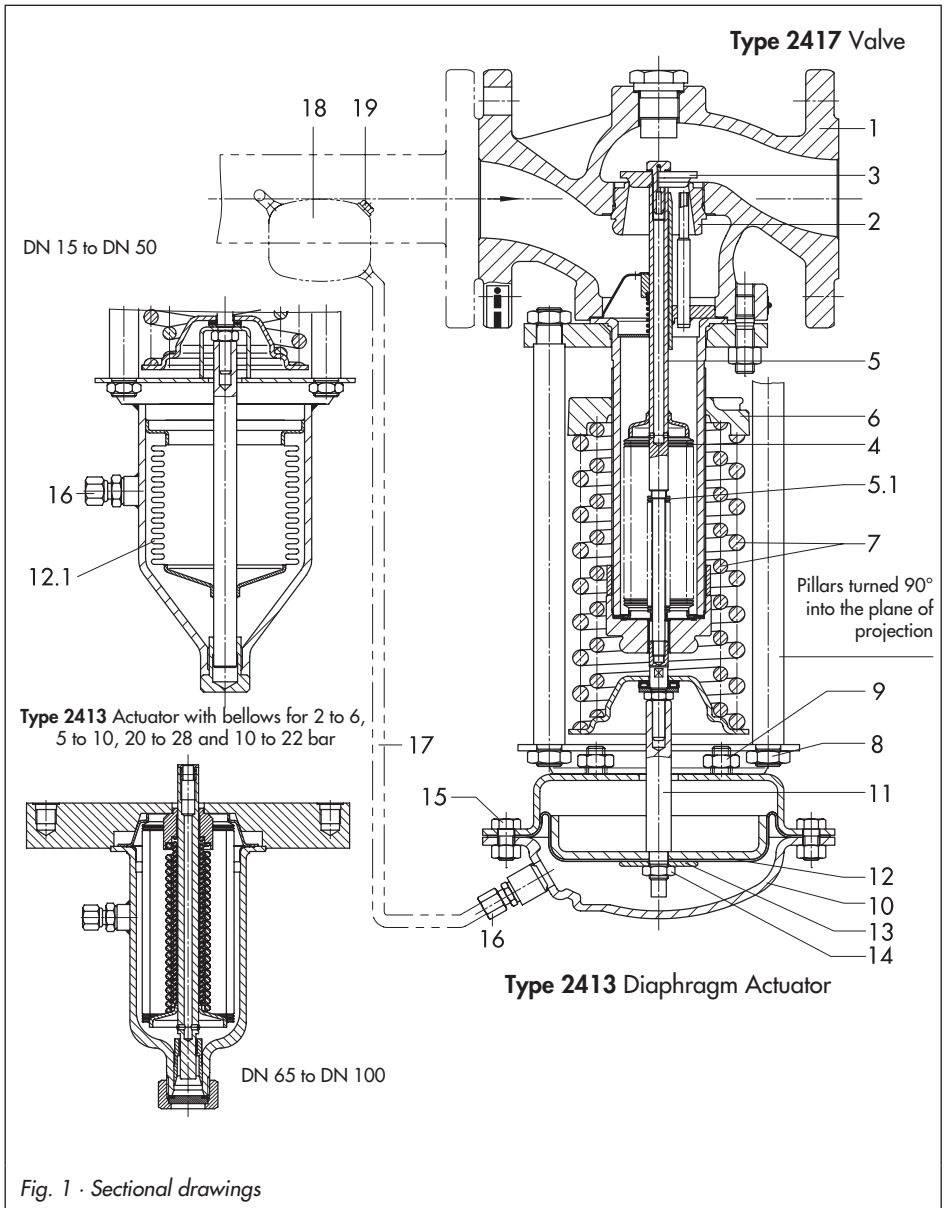

2.2 Mounting position

NOTICE

Protect the regulator from icing up when controlling media that can freeze. Remove the regulator from the pipeline when the plant is shut down if the regulator is not installed in areas free from frost.

Flush the pipeline thoroughly before installing the regulator to ensure that any sealing parts, weld spatter and other impurities carried along by the process medium do not impair the proper functioning of the valve, above all the tight shut-off.

NOTICE

Install a strainer (e.g. SAMSON Type 2) upstream of the regulator (see section 2.4).

Install the excess pressure valve in a horizontal pipeline. On installing the valve, make sure the direction of flow corresponds with the arrow on the body. For media with a tendency to condensate, install the pipeline with a slight downward slope on both sides so that the condensate can drain properly. If the pipeline upstream and downstream of the valve run vertically upwards, an automatic water drainage (SAMSON Type 13E Steam Trap) is required. Make sure you choose a place of installation that allows you to freely access the regulator even after the entire plant has been completed. The regulator must be installed free of stress. If necessary, support the piping near the connections.



Standard mounting position for medium temperatures above 0 °C. Not permissible for millibar pressure regulators.

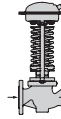

Mounting position for gases and liquids with medium temperatures up to 80 °C.

Mounting position compulsory for millibar pressure regulators.

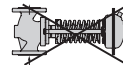

Not permissible!

Fig. 2 · Mounting positions

NOTICE

Do not attach supports directly to the valve or actuator.

If a bypass line is to be used, it must be connected downstream of the pressure tapping point. Install a shut-off valve in the bypass line.

Notice: Do not install any instruments (e.g. temperature regulators or shut-off valves) which restrict the cross-section of the pipe between the pressure tapping point and the valve.

2.3 Control line, condensation chamber and needle valve

Control line · A control line must be provided at the site of installation, e.g. a $\frac{3}{8}$ " pipe for steam and an 8 x 1 or 6 x 1 mm pipe for air/water.

Connect the control line to the upstream line (p_1) at least one meter away from the valve inlet.

Weld the control line at the side in the middle of the pipe, inclining at a ratio of approximately 1:10 up to the condensation chamber.

Control line kit · A control line kit for tapping pressure directly at the valve body is available as an accessory from SAMSON.

Condensation chamber · Refer to Table 1. A condensation chamber is required for liquids above 150 °C as well as for steam. The

mounting position of the condensation chamber is indicated by an adhesive label on the chamber itself as well as by an arrow and the word "top" stamped onto the top of the chamber.

This mounting position must be adhered to; otherwise the safe functioning of the excess pressure valve cannot be guaranteed.

Weld the line coming from the pressure tapping point to the $\frac{3}{8}$ " pipe socket on the chamber. Install the condensation chamber at the highest point of the pipeline. Consequently, the control line between condensation chamber and actuator must also be installed with a downward slope. In this case, use a $\frac{3}{8}$ " pipe with screw fittings.

If the control line connection is located below the middle of the valve inlet flange, arrange the condensation chamber at the same level

Table 1 · Assignment of condensation chamber (4) to regulator

Actuator A in cm ²	Item no. · Condensation chamber	
	DN 15 to DN 50	DN 65 to DN 250
640	1190-8789	1190-8790
320	1190-8788	1190-8789
160/80/40	1190-8788	

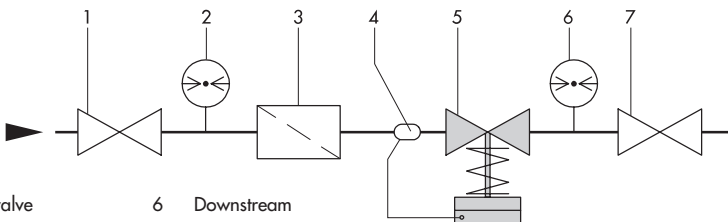

- 1 Shut-off valve
- 2 Upstream pressure gauge
- 3 Strainer
- 4 Condensation chamber
- 5 Excess pressure valve
- 6 Downstream pressure gauge
- 7 Shut-off valve

NOTICE
Always install millibar pressure regulators upright with actuator on top.

Fig. 3 · Examples of installation with steam

as the inlet flange. In this case, use a pipe which is at least 1/2" in size for the control line from the tapping point to the condensation chamber.

If the control line is connected above the middle of the valve inlet flange, install the condensation chamber at the same level of the upstream pressure tapping point. The additional pressure of the condensate head must be compensated for by adjusting the set point to a higher value.

Needle valve · If the regulator tends to hunt, we recommend installing a SAMSON screw joint with restriction (needle valve) at the control line connection (16).

2.4 Strainer

The strainer must be installed upstream of the excess pressure valve. Make sure the direction of medium flow corresponds with the direction indicated by the arrow on the strainer. The filter element must be suspended to hang downwards. Remember to leave enough space to remove it.

2.5 Shut-off valve

We recommend installing a hand-operated shut-off valve both upstream of the strainer and downstream of the regulator to be able to shut down the plant for cleaning and maintenance, and when the plant is not used for longer periods of time.

2.6 Pressure gauge

To monitor the pressures in the plant, install a pressure gauge both upstream and downstream of the regulator. Install the pressure gauge on the upstream side in front of the

upstream pressure tapping point (not between the tapping point and the valve!).

3 Operation

3.1 Start-up

First start up the regulator after mounting all the components. Make sure the control line is open and correctly connected.

Fill the plant **s l o w l y** with the process medium.

NOTICE

The permissible pressure at the actuator must not be exceeded on testing the pressure of the plant (refer to Technical data in section 8).

The maximum permissible differential pressure for millibar excess pressure valves (1200 cm² actuator) is 10 bar. The maximum permissible pressure at the actuator must not exceed 0.5 bar.

For regulating steam

Unscrew filler plug (19) on the condensation chamber. Use the included plastic funnel or a jug to pour in water until it starts to overflow. Screw the filler plug back in and tighten it. The excess pressure valve is now ready for operation.

Open the hand-operated shut-off valves slowly to prevent water hammer.

For regulating liquid

To start up the excess pressure valve, open shut-off valves slowly. For actuators with an effective diaphragm area of 640 cm², loosen the vent screw. Allow all the air to escape, then retighten it. For temperatures above

150 °C, first fill the required condensation chamber with the process medium.

3.2 Set point adjustment

The required upstream pressure is set by turning the set point adjustment (6) using an open-end wrench up to DN 50 with width across flats SW 19 and for DN 65 and larger with SW 22. Turn clockwise to increase the upstream pressure and turn counterclockwise to reduce it.

The pressure gauge located on the upstream pressure side (in front of the valve) allows the adjusted set point to be monitored.

An initial adjustment of the set point can also be made by turning the set point adjustment until the **distance x** (see Fig. 4) is reached.

Table 2 lists the set points and their assigned **distance x** for the regulators and their various set point ranges.

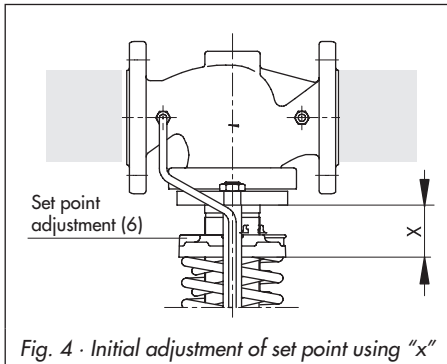

Fig. 4 · Initial adjustment of set point using "x"

Table 2 · Initial adjustment of the set point

Set point range	Nominal size DN		
8 to 16 bar	15 to 25	32 to 50	65 to 100
Set point 10 bar	x = 74 mm	x = 91 mm	x = 133 mm
12 bar	x = 82 mm	x = 102 mm	x = 150 mm
14 bar	x = 89 mm	x = 113 mm	x = 168 mm
4.5 to 10 bar			
Set point 5.9 bar	x = 70 mm	x = 85 mm	x = 131 mm
7.3 bar	x = 78 mm	x = 97 mm	x = 152 mm
8.6 bar	x = 86 mm	x = 103 mm	x = 172 mm
2 to 5 bar			
Set point 2.8 bar	x = 68 mm	x = 82 mm	x = 126 mm
3.5 bar	x = 77 mm	x = 95 mm	x = 148 mm
4.3 bar	x = 85 mm	x = 107 mm	x = 170 mm
0.8 to 2.5 bar			
Set point 1.2 bar	x = 64 mm	x = 77 mm	x = 117 mm
1.7 bar	x = 74 mm	x = 91 mm	x = 142 mm
2.1 bar	x = 84 mm	x = 106 mm	x = 167 mm
0.2 to 1.2 bar			
Set point 0.45 bar	x = 56 mm	x = 66 mm	x = 98 mm
0.70 bar	x = 68 mm	x = 83 mm	x = 127 mm
1.0 bar	x = 80 mm	x = 100 mm	x = 157 mm
0.1 to 0.6 bar			
Set point 0.23 bar	x = 56 mm	x = 66 mm	x = 98 mm
0.35 bar	x = 68 mm	x = 83 mm	x = 127 mm
0.48 bar	x = 80 mm	x = 100 mm	x = 157 mm
0.05 to 0.25 bar			
Set point 0.10 bar	x = 55 mm	x = 65 mm	x = 92 mm
0.15 bar	x = 66 mm	x = 80 mm	x = 116 mm
0.20 bar	x = 76 mm	x = 95 mm	x = 139 mm

3.3 Decommissioning

Close first the shut-off valve on the upstream side of the valve and then on the downstream side of the valve.

4 Cleaning and maintenance

The excess pressure valve is maintenance free. Nevertheless, it is subject to natural wear, particularly at the seat, plug and operating diaphragm.

Depending on the operating conditions, the regulator needs to be checked at regular intervals to avoid possible malfunctions. Details on faults and how to remedy them can be found in Table 3 on page 11.

CAUTION!

On performing any work on the pressure regulator, make sure the relevant section of the pipeline is depressurized and, depending on the process medium, drained as well. We recommend to remove the valve from the pipeline.

For high temperatures, allow the regulator to cool down to ambient temperature before starting any work on it.

Interrupt or shut off the control line to avoid any hazards which could be caused by moving parts.

As valves are not free of cavities, remember that residual process medium might still be contained in the valve. This applies in particular to valve versions with a balancing bellows.

NOTICE

Make absolutely sure that no torque is applied to the bellows seal (5.1) during assembly or disassembly. Otherwise, the metal bellows will be destroyed.

4.1 Replacing the operating diaphragm

If the upstream pressure deviates from the set point considerably, check if the diaphragm is leaking and, if necessary, replace it.

1. Shut down the plant by slowly closing the shut-off valves. Relieve the relevant section of the pipeline of pressure and, if necessary, drain it as well.
2. Unscrew the control line (17) and clean it.
3. Loosen the bolts (15) at the actuator and remove the cover plate.
4. Unscrew the nut (14) and lift off the diaphragm plate (13).
5. Replace the operating diaphragm (12) with a new one.
6. Proceed in the reverse order to reassemble the regulator. For start-up, proceed as described in section 3.1.

Table 3 · Troubleshooting

Fault	Possible reasons	Remedy
Pressure exceeds the adjusted set point	Insufficient pressure pulses on the actuator diaphragm	Clean the control line and the screw joint with restriction.
	Seat and plug worn down by deposits or foreign particles	Disassemble the regulator and replace damaged parts.
	Pressure tapped at the wrong place	Reconnect control lines at a different place. Do not tap pressure at pipe bends or necks.
	With steam: Condensation chamber in the wrong position or too small	Reconnect chamber at a different place or replace it (see p. 7, Table 1 and sec. 2.3).
	Control response too slow	Install larger screw joint at the diaphragm actuator.
	Foreign particles blocking the plug	Disassemble the regulator and replace damaged parts.
	Valve installed against the flow; see arrow on body	Check direction of flow. Install valve correctly.
Pressure drops below the adjusted set point	Pressure tapped at the wrong place	Reconnect control lines at a different place.
	With steam: Condensation chamber in the wrong position or too small	Reconnect chamber at a different place or replace it (see p. 7, Table 1 and sec. 2.3).
	Foreign particles blocking the plug	Disassemble the regulator and replace damaged parts.
Jerky control response	Increased friction, e.g. due to foreign particles between seat and plug	Remove foreign particles. Replace damaged parts.
Slow control response	Restriction in the screw joint of the actuator dirty or too small	Remove foreign particles. Replace damaged parts.
	Dirt in the control line	Clean the control line.
Upstream pressure fluctuates	Valve too large	Check valve sizing. Select smaller K_{VS} coefficient, if necessary.
	Restriction in the screw joint of the actuator too large	Install smaller screw joint.
	Pressure tapped at the wrong place	Select better place for pressure tapping.
Loud noises	High flow velocity, cavitation	Check sizing. Install flow divider with gases and steam.

5 Customer service

Should any malfunctions or any defect occur, SAMSON's After-Sales Service is prepared to help you on site.

You can also send the defective regulator directly to your local SAMSON representative for repair. Addresses of SAMSON subsidiaries, agencies and service centers are listed in the product catalogs and in the Internet at www.samson.de.

To allow SAMSON to find the fault and to have an idea of the installation situation, specify the following details (refer to the nameplate):

- ▶ Type and nominal size of the valve
- ▶ Model number with index
- ▶ Upstream and downstream pressure
- ▶ Temperature and control medium
- ▶ Minimum and maximum flow rate
- ▶ Has a strainer been installed?
- ▶ Sketch of the installation with exact position of regulator and all additional installed components (shut-off valves, pressure gauges, etc.).

6 Dimensions

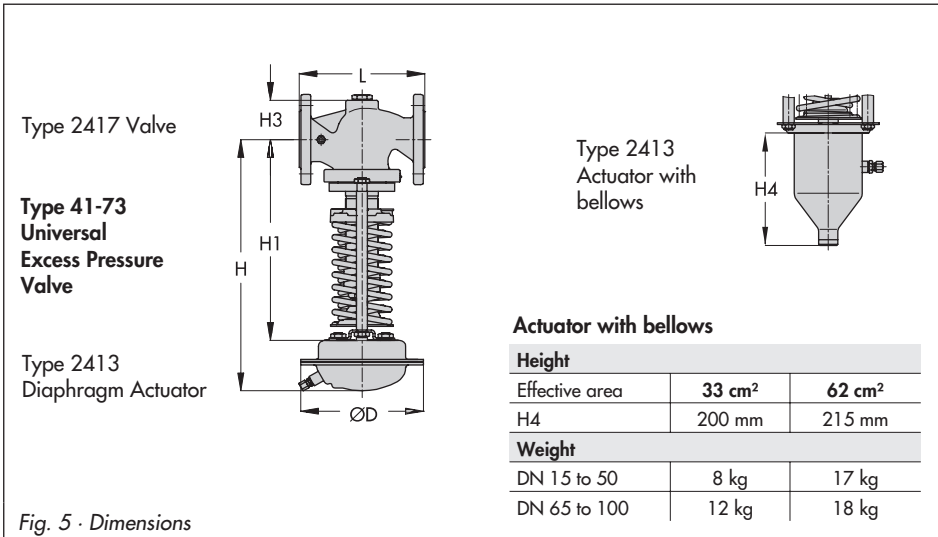

Table 4 · Dimensions in mm and weights

Excess Pressure Valve		Type 41-73									
Nominal size		DN	15	20	25	32	40	50	65	80	100
Set point range in bar	Length L		130	150	160	180	200	230	290	310	350
	Height H1		315			370			500		515
	Height H3	Other materials	55			72			100		120
		Forged steel	53	–	70	–	92	98	–	128	–
0.005 to 0.03	Height H		425								
	Actuator		Ø D = 490 mm, A = 1200 cm ²								
	Valve spring force F		600 N								
0.025 to 0.05	Height H		425			480			610		
	Actuator		Ø D = 490 mm, A = 1200 cm ²								
	Valve spring force F		1200 N								
0.05 to 0.25	Height H		425			480			610		625
	Actuator		Ø D = 380 mm, A = 640 cm ²								
	Valve spring force F		1750 N								
0.1 to 0.6	Height H		425			480			610		625
	Actuator		Ø D = 380 mm, A = 640 cm ²								
	Valve spring force F		4400 N								
0.2 to 1.2	Height H		410			460			590		610
	Actuator		Ø D = 285 mm, A = 320 cm ²								
	Valve spring force F		4400 N								
0.8 to 2.5	Height H		410			465			595		610
	Actuator		Ø D = 225 mm, A = 160 cm ²								
	Valve spring force F		4400 N								
2 to 5	Height H		390			445			575		590
	Actuator		Ø D = 170 mm, A = 80 cm ²								
	Valve spring force F		4400 N								
4.5 to 10	Height H		390			445			575		590
	Actuator		Ø D = 170 mm, A = 40 cm ²								
	Valve spring force F		4400 N								
8 to 16	Height H		390			445			575		590
	Actuator		Ø D = 170 mm, A = 40 cm ²								
	Valve spring force F		8000 N								
0.005 to 0.05	Weight, based on cast iron ¹⁾ , approx. kg		28.5	29.5	35.5	37.5	41	57	64	–	
0.05 to 0.6			22.5	23.5	29.5	31.5	35	51	58	67	
0.2 to 2.5			16	18	23.5	25.5	29	45	52	61	
2 to 16			12	13	18.5	21	24	40	47	56	

1) +10 % for other materials

7 Nameplates

A nameplate is attached to the valve and actuator.

Valve nameplates

DIN version

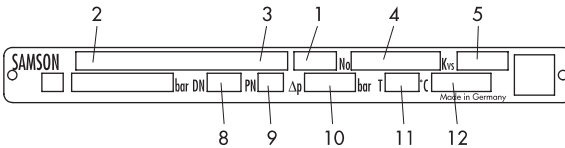

ANSI version

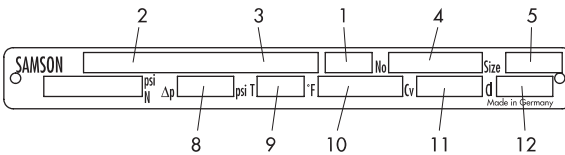

DIN version

- 1 Valve type
- 2 Model number
- 3 Model number index
- 4 Order number or order date
- 5 K_{VS} coefficient
- 8 Nominal size
- 9 Nominal pressure
- 10 Perm. differential pressure
- 11 Perm. temperature
- 12 Body material

ANSI version

- 5 Nominal size
- 8 Perm. differential pressure
- 9 Perm. temperature (°F)
- 10 Body material
- 11 C_V coefficient ($K_{VS} \times 1.17$)
- 12 ANSI Class (pressure rating)

Actuator nameplate

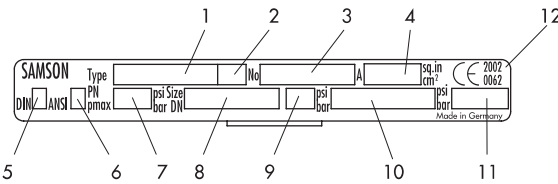

- 1 Model number
- 2 Model number index
- 3 Order number or order date
- 4 Effective area
- 5 Labeling acc. to DIN
- 6 Labeling acc. to ANSI
- 7 Max. perm. pressure
- 8 Nominal size
- 9 Differential pressure
- 10 Set point range
- 11 Diaphragm material
- 12 Year of manufacture

Fig. 6 · Nameplates

8 Technical data

Table 5 · Technical data · All pressures in bar (gauge)

Valve		Type 2417		
Nominal pressure	PN	16, 25 or 40		
Nominal size	DN	15 to 50	65 to 80	100
Max. perm. differential pressure Δp		25 bar ¹⁾	20 bar ¹⁾	16 bar
Temperature ranges		Refer to T 2517 EN · Pressure-temperature diagram		
	Valve plug	Metal sealing: max. 350 °C · Soft PTFE sealing: max. 220 °C Soft EPDM or FPM sealing: max. 150 °C · Soft NBR sealing: max. 60 °C		
Leakage rate (standard version)		Metal sealing: Leakage class I ≤ 0.05 % of Kvs Soft sealing: Leakage class IV		
Diaphragm actuator		Type 2413		
Set point ranges		5 to 30 mbar ²⁾ · 25 to 50 mbar ²⁾ · 0.05 to 0.25 bar · 0.1 to 0.6 bar 0.2 to 1.2 bar · 0.8 to 2.5 bar · 2 to 5 bar · 4.5 to 10 bar 8 to 16 bar		
Max. perm. pressure at actuator		1.5 x max. set point of the actuator ³⁾		
Max. perm. temperature		Gases 350 °C, however, at actuator max. 80 °C Liquids 150 °C, with condensation chamber max. 350 °C Steam with condensation chamber max. 350 °C		
Actuator with bellows		Type 2413		
Effective area		33 cm ²	62 cm ²	
Max. perm. pressure at actuator		30 bar	20 bar	
Set point ranges		10 to 22 bar 20 to 28 bar	2 to 6 bar ⁴⁾ 5 to 10 bar	
Positioning spring		8000 N		

1) For millibar excess pressure valve: max. perm. differential pressure Δp : 10 bar

2) Only for millibar excess pressure valve

3) Millibar excess pressure valve: max. 0.5 bar

4) Positioning spring 4400 N



SAMSON AG · MESS- UND REGELTECHNIK
Weismüllerstraße 3 · 60314 Frankfurt · Germany
Phone: +49 69 4009-0 · Fax: +49 69 4009-1507
Internet: <http://www.samson.de>

EB 2517 EN

S/Z/2008-01