

GESTRA Steam Systems

Product Range A1

Condensate Lifter UNA 25-PS, PN 40, DN 40

UNA 25-PS

Description

Float-operated condensate lifter, designed for effective return of condensate. Steam is used as motive power for the operating cycle that displaces condensate out of the trap body.

The control mechanism consists of a control unit with ball float, a changeover linkage and a valve block for controlling the motive steam inlet and the vent outlet. The equipment features integrated inlet and outlet check valves, a connection for motive steam and a connection for the vent valve.

Function

The condensate flows through the integrated check valve into the trap body. When the float reaches its upper tripping point, it will switch the valve block. In this valve block the vent valve will be closed and the motive steam valve opened. The pressure now supplied by the motive steam forces the condensate out of the trap body. When the lower tripping point is reached, the position of the float will cause the valve block to open the vent valve and close the motive steam valve. Condensate flows again through the check valve into the trap body, and a new discharge cycle begins for the condensate lifter. During the pumping process condensate collects in the supply line of the condensate lifter.

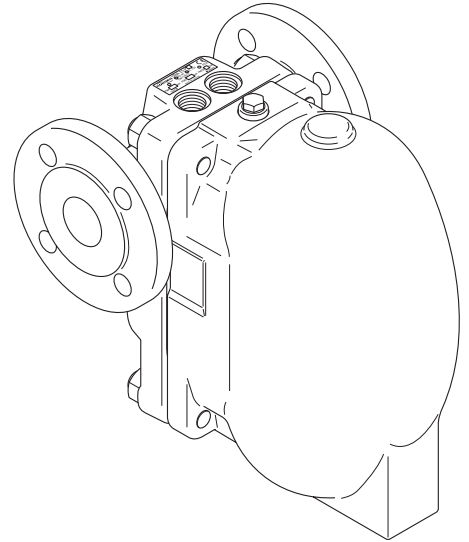

UNA 25-PS

Pressure /Temperature Ratings & End Connections

| Flanged PN 40, EN 1092-2, DN 40 | | | | | | | |
|----------------------------------|--------|------|------|------|------|--|--|
| PMA (max. allowable pressure) | [barg] | 40.0 | 38.3 | 31.6 | 25.0 | | |
| TMA (max. allowable temperature) | [°C] | 20 | 120 | 250 | 350 | | |
| PMO (max. pressure) | [bar] | 13 | | | | | |
| PMOB (max. back pressure) | [bar] | 5 | | | | | |

| Flanged Class 150, ASME B16.5, DN 40 | | | | | | | |
|--------------------------------------|--------|------|------|------|-----|--|--|
| PMA (max. allowable pressure) | [barg] | 17.2 | 13.9 | 12.1 | 6.6 | | |
| TMA (max. allowable temperature) | [°C] | 20 | 200 | 250 | 350 | | |
| PMO (max. pressure) | [bar] | 13 | | | | | |
| PMOB (max. back pressure) | [bar] | 5 | | | | | |

| Screwed sockets to EN ISO 228-1, 1½" | | | | | | | |
|--------------------------------------|--------|------|------|------|------|--|--|
| PMA (max. allowable pressure) | [barg] | 40.0 | 38.3 | 31.6 | 25.0 | | |
| TMA (max. allowable temperature) | [°C] | 20 | 120 | 250 | 350 | | |
| PMO (max. pressure) | [bar] | 13 | | | | | |
| PMOB (max. back pressure) | [bar] | 5 | | | | | |

| Screwed sockets NPT, ASME B1.20.1, 1½" | | | | | | | |
|--|--------|------|------|------|------|--|--|
| PMA (max. allowable pressure) | [barg] | 40.0 | 38.3 | 31.6 | 25.0 | | |
| TMA (max. allowable temperature) | [°C] | 20 | 120 | 250 | 350 | | |
| PMO (max. pressure) | [bar] | 13 | | | | | |
| PMOB (max. back pressure) | [bar] | 5 | | | | | |

Materials

| Type | UNA 25-PS | |
|-------------|-----------------|-----------------|
| Designation | DIN / EN | ASTM* |
| Body | EN-JS 1049 | A 395 |
| Cover | EN-JS 1049 | A 395 |
| Internals | Stainless steel | Stainless Steel |

*) Physical and chemical properties comply with DIN grade. ASTM nearest equivalent grade is stated for guidance only

Dimensions

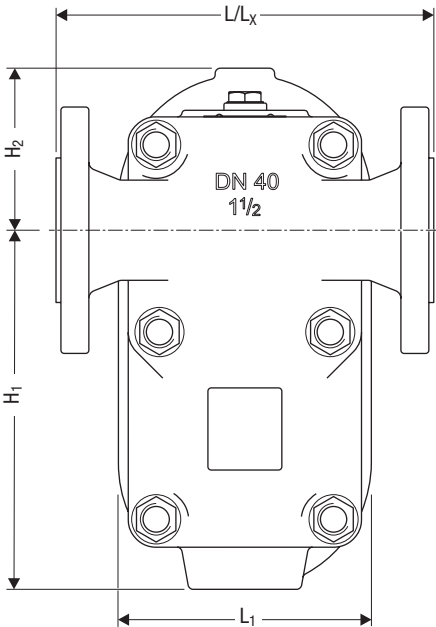
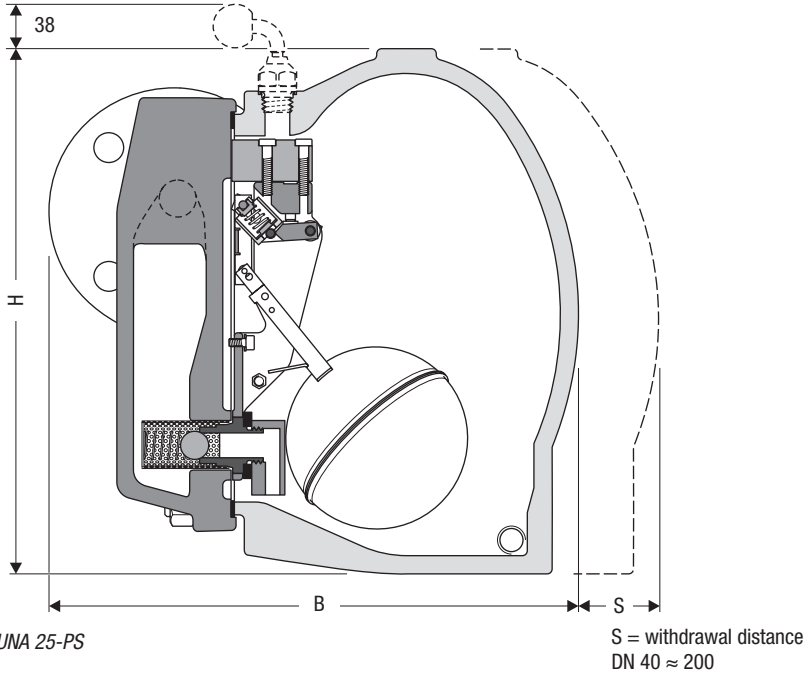

With flanged connection (UNA 25-PS)

L = Length of installation for UNA 25-PS, end connection: flanged to DIN / EN.

L_x = Length of installation for UNA 25-PS, end connection: flanged to Class 150 and screwed sockets G / NPT.

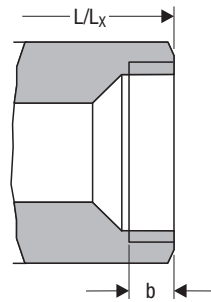

With screwed sockets (UNA 25-PS)

L = Length of installation for UNA 25-PS, end connection: flanged to DIN / EN.

L_x = Length of installation for UNA 25-PS, end connection: flanged to Class 150 and screwed sockets G / NPT.

b = Thread depth of screwed socket G / NPT.

Dimensions - continued -

| DN | [mm] | 15 | 20 | 25 | 40 | 50 |
|-----------|----------------|----|----|----|------|----|
| | [inch] | ½ | ¾ | 1 | 1½ | 2 |
| UNA 25-PS | L | | | | 230 | |
| | L _x | | | | 227 | |
| | L ₁ | | | | 154 | |
| | B | | | | 325 | |
| | H | | | | 318 | |
| | H ₁ | | | | 219 | |
| | H ₂ | | | | 99 | |
| | b (G) | | | | 21.4 | |
| | b (NPT) | | | | 17.3 | |

L = Length of installation for UNA 25-PS, end connection: flanged to DIN / EN.

L_x = Length of installation for UNA 25-PS, end connection: flanged to Class 150 and screwed sockets G / NPT.

b = Thread depth of screwed socket G / NPT.

Weights

| UNA 25-PS | | | | | | | |
|-----------------|------|--------|----|----|----|----|----|
| End connection | | DN | | | | | |
| | | [mm] | 15 | 20 | 25 | 40 | 50 |
| | | [inch] | ½ | ¾ | 1 | 1½ | 2 |
| Flanged | [kg] | | | | | 31 | |
| Screwed sockets | [kg] | | | | | 26 | |

Component Parts of UNA 25-PS

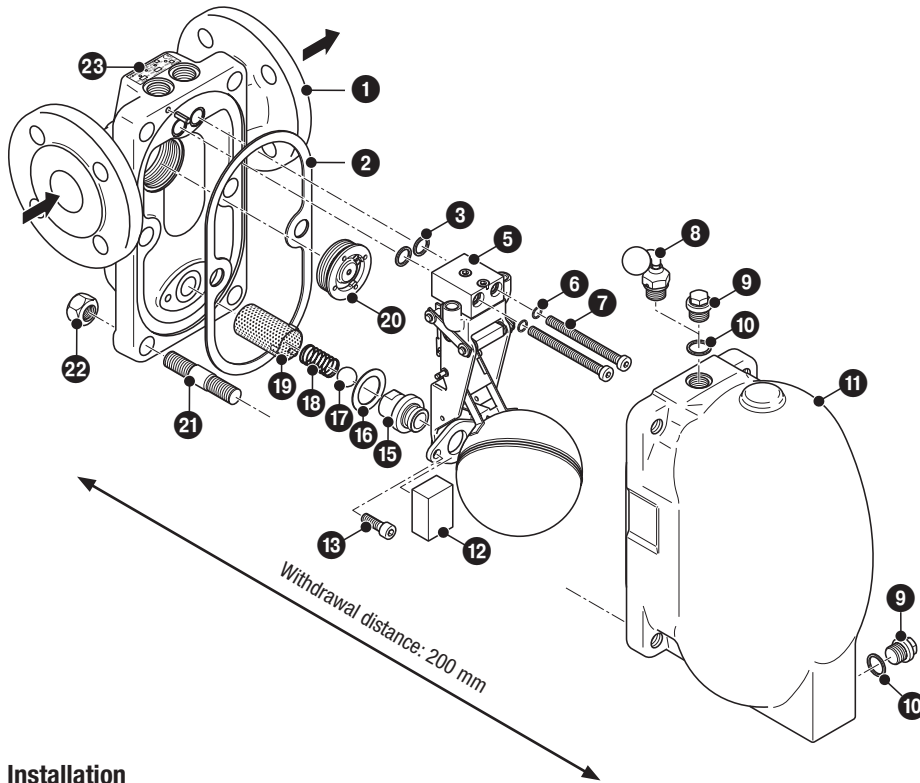

Installation

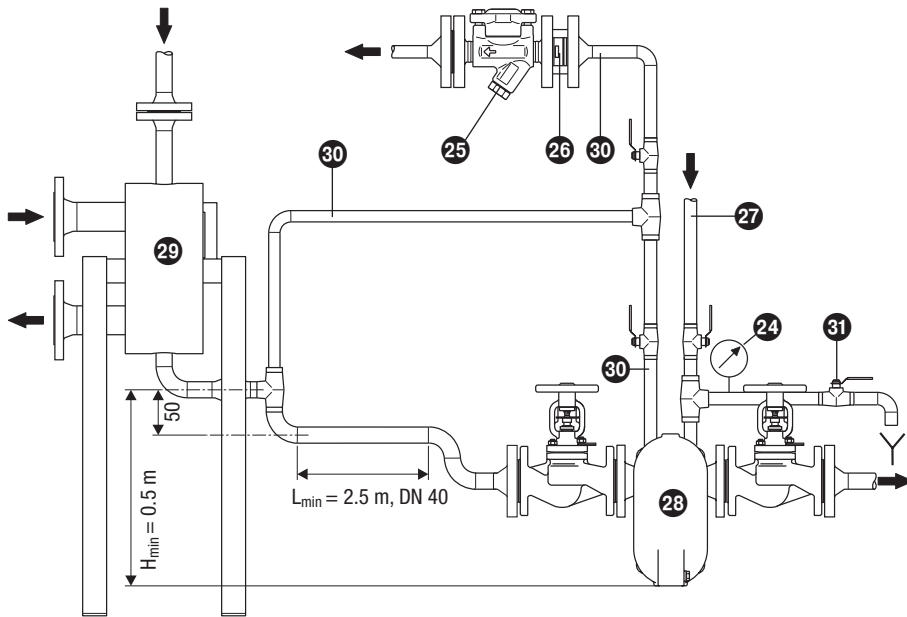

Connection of UNA 25-PS to heat exchanger or condensate line with vent line returned (hot condensate, supply not pressureless)

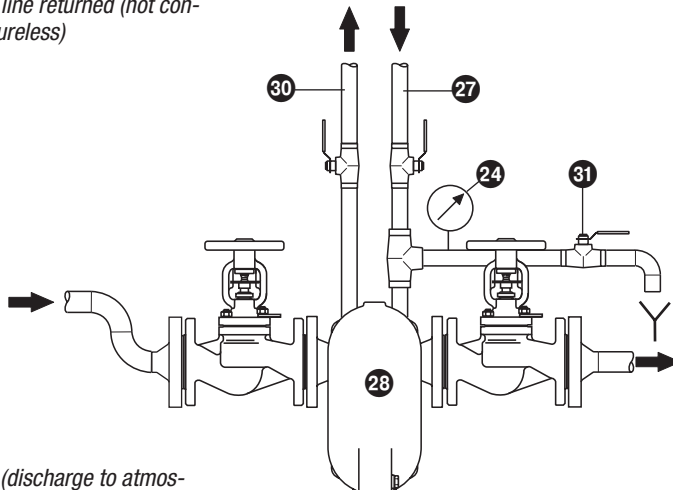

Connection of UNA 25-PS (discharge to atmosphere, supply pressureless, recovery of highly undercooled condensates).

Key

- 1 Body
- 2 Body gasket (graphite/CrNi)
- 3 Gasket
- 4 Control unit UNA 25-PK
- 5 Control unit UNA 25-PS
- 6 Gasket
- 7 Socket-head cap screw
- 8 Hand vent valve
- 9 Sealing plug
- 10 Gasket
- 11 Cover
- 12 Deflection block
- 13 Socket-head cap screw
- 14 Seat (orifice)
- 15 Seat (condensate lifter)
- 16 Seat gasket
- 17 Ball (outlet check valve)
- 18 Spring (outlet check valve)
- 19 Wear protection
- 20 Inlet check valve
- 21 Stud bolt
- 22 Hexagon nut
- 23 Name plate
- 24 Pressure gauge
- 25 Thermostatic steam trap, e.g. MK... for de-aeration. (Alternatively mounted to vent hole 9 (3/8") of UNA 25-PS)
- 26 Check valve (optional), prevents air from entering the equipment if there is a vacuum.
- 27 Motive steam, drained, DN 15 (1/2").
- 28 UNA 25-PS
- 29 Heat exchanger
- 30 Vent line, DN 15 (1/2")
- 31 Pressure-reducing valve

Please note:

A motive steam line must be connected via female thread 1/2".

The max. motive steam pressure is 6 barg.

A balance line must be connected via female thread 1/2".

There must be a minimum supply head of 0.5 m between the heat exchanger and the UNA 25-PK.

The supply line must be at least 2.5 m long in order to ensure enough buffer volume. Alternatively a buffer reservoir with a volume of 3 litres can be used.

Condensate Lifter UNA 25-PS, PN 40, DN 40

Flow Characteristics

The tables show the maximum capacities for hot and cold condensate.

The capacities are dependent on the differential pressure (working pressure). The differential pressure is the difference between inlet and outlet pressure and depends among other things on the run of the condensate line. If the condensate downstream of the condensate lifter is lifted, the differential pressure is reduced by approximately 1 bar for 7 m lift.

The max. admissible differential pressure depends on the density of the fluid to be lifted.

Inspection & Certification

Documentation regarding material tests and in-house examination with test report EN10204-2.2 available at extra cost. All inspection requirements have to be stated with the enquiry or order. After supply of the equipment certification cannot be established. Charges and extent of the above mentioned test certificates as well as the different tests confirmed therein are listed in our Price List "Test and Inspection Charges for Standard Equipment". For other tests and inspections than those listed above, please consult us.

PED (Pressure Equipment Directive)

The equipment fulfills the requirements of the Pressure Equipment Directive PED 97/23/EC. For use with fluids of group 2. With CE marking (apart from equipment that is excluded from the scope of the PED as specified in section 3.3).

ATEX (Atmosphère Explosible)

The equipment does not have its own potential source of ignition and is therefore not subject to the ATEX Directive 94/9/EC. Applicable in Ex zones (surrounding atmosphere) 0, 1, 2, 20, 21, 22 (1999/92/EC). The equipment is not Ex marked.

Supply in accordance with our general terms of business.

Flowrate (condensate lifting mode)

| Condensate (hot water) Flowrate at 13 bar motive steam pressure and 1 m supply head | | | |
|---|--------|-----|--|
| Flowrate | [kg/h] | 600 | |
| PMOB (operating back pressure) | [bar] | 1 | |

Flowrate at 6 bar motive steam pressure and 1 m supply head

| Cold water Flowrate at 13 bar motive steam pressure and 1 m supply head | | | |
|---|--------|-----|--|
| Flowrate | [kg/h] | 800 | |
| PMOB (operating back pressure) | [bar] | 1 | |

Spare parts list for UNA 25-PS

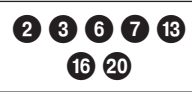
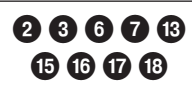
| Item | Designation | Stock code |
|---|--|------------|
| | | DN 40 |
|  | Control unit UNA 25-PS, screws, gaskets, seat gasket, body gasket | 560594 |
|  | Inlet check valve, screws, gaskets, seat gasket, body gasket | 560595 |
|  | Outlet check valve (cpl.), seat, screws, gaskets, seat gasket, body gasket | 560598 |

GESTRA AG

P. O. Box 10 54 60, D-28054 Bremen
Münchener Str. 77, D-28215 Bremen
Telephone 0049 (0) 421 35 03 - 0, Fax 0049 (0) 421 35 03-393
E-mail gestra.gmbh@flowserve.com, Internet www.gestra.de

